

LA CALIDAD A SU SERVICIO

Diseño, fabricación y mantenimiento de herramientas de corte.

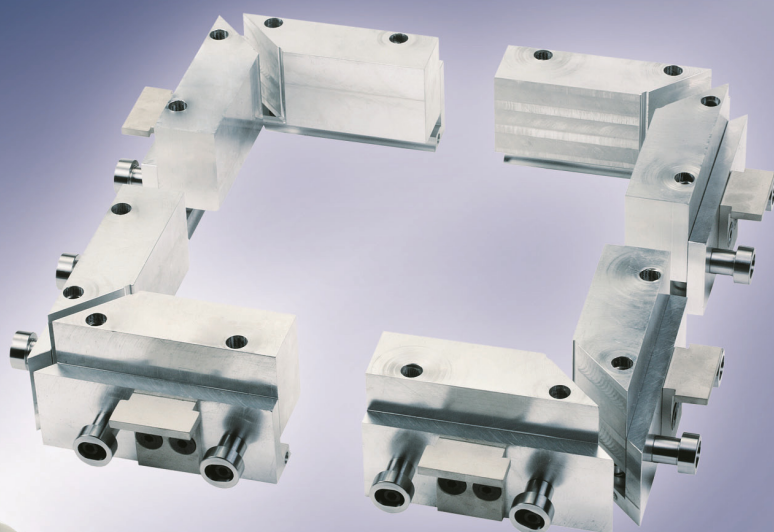

CATÁLOGO PVC

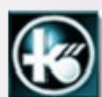

KÖMMERLING®

Hegasa

HERRAMIENTAS DE GALICIA S.A.

ÍNDICE

PVC

KÖMMERLING EUROFUTURE	PAG. 1 - 8
KÖMMERLING SERIE EURODUR	PAG. 9 - 15
KÖMMERLING SERIE FRANCESA	PAG. 16 - 17
KÖMMERLING CORREDERA PREMILINE	PAG. 18 - 20
KÖMMERLING FRAILERO — CONTRAVENTANA	PAG. 21
KÖMMERLING ELEVADORA	PAG. 22 - 23
KÖMMERLING CORREDERA SF3	PAG. 25 - 25
KÖMMERLING MALLORQUINA	PAG. 26 - 27
KÖMMERLING PLANTILLA JUNQUILLOS	PAG. 28
PIEZAS ACOPLA A MAQUINAS SOLDAR	PAG. 29 - 32
HUSILLOS PORTA HERRAMIENTAS	PAG. 33 - 35
DISCOS DE CORTE	PAG. 36 - 39
BROCAS Y MANDRINOS PORTA PINZAS	PAG. 40 - 43
ANILLOS SEPARADORES - ANILLOS DECIMALES	PAG. 44 - 45



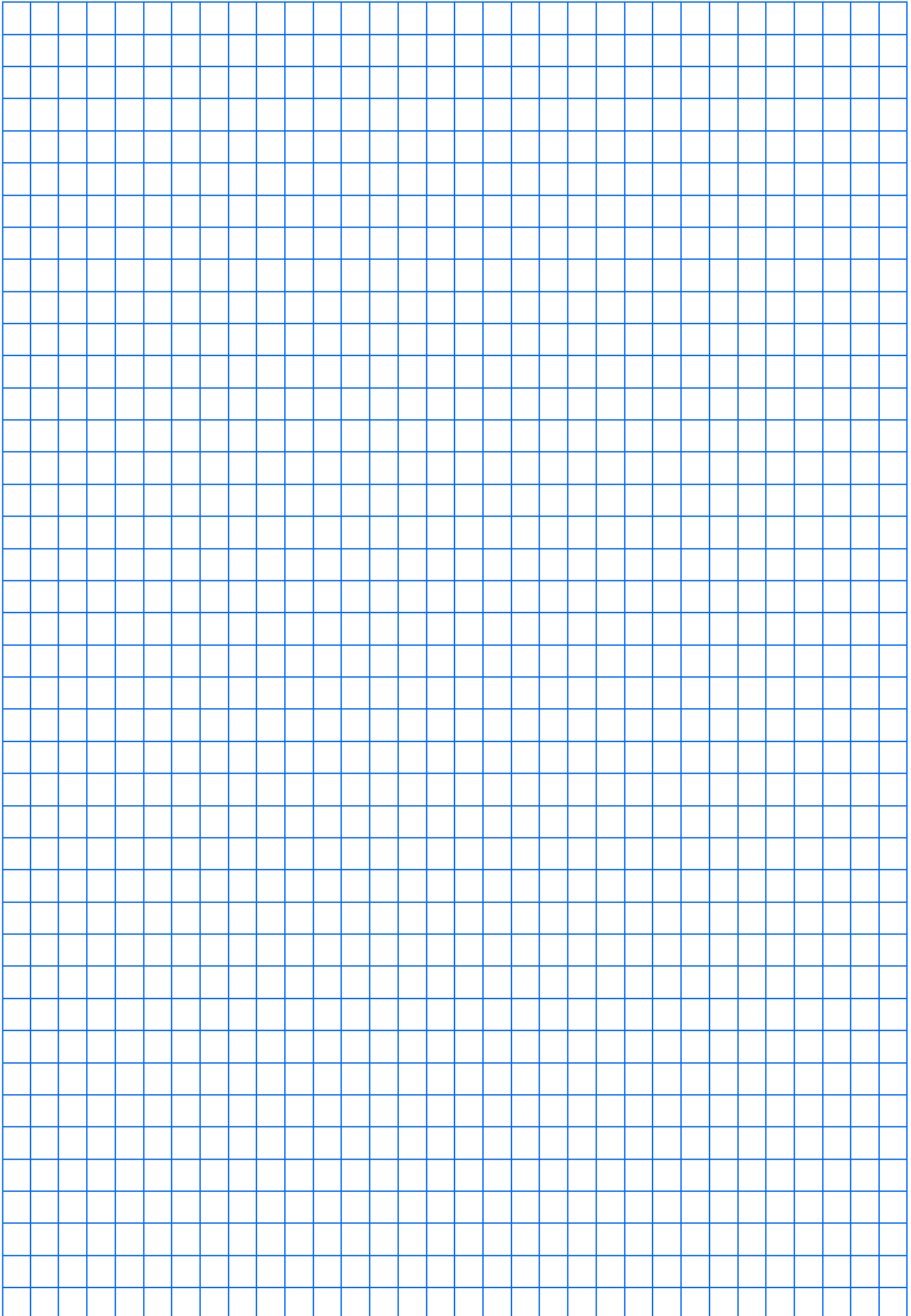

PVC



KÖMMERLING®

**FRESA RECTA LIMPIEZA TODOS LOS MARCOS
PERFILES SERIES . EURO FUTURE
EURODUR
CORREDERAS**

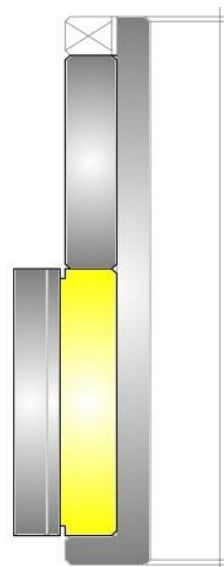

**CONJUNTO FRESA LIMPIEZA MARCOS
PERFILES : 0001—0102**

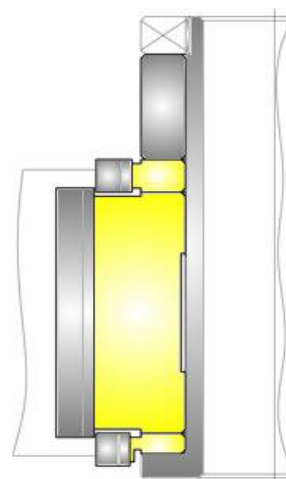

**CONJUNTO FRESA LIMPIEZA MARCO RENOVACION
PERFILE : 0004**

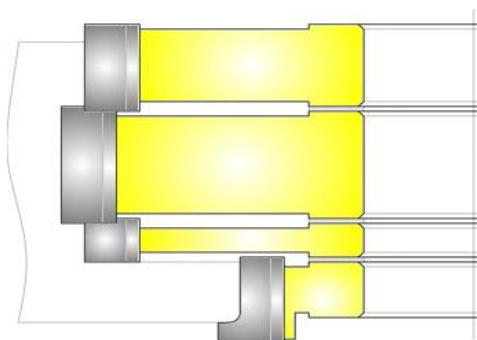

**CONJUNTO FRESA LIMPIEZA MARCO RENOVACION
PERFILE : 0105**

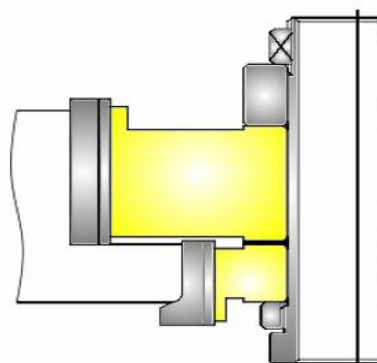

EN EL PRECIO NO ESTAN INCLUIDOS LOS HUSILLOS PORTA HERRAMIENTAS

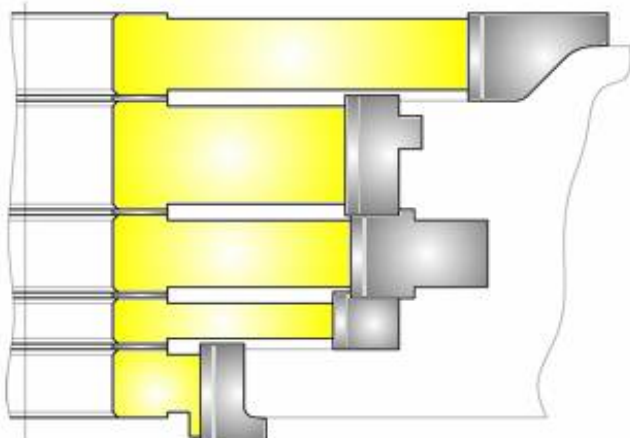

**CONJUNTO LIMPIEZA LIMPIEZA HOJAS
PERFILES REF: 0011 / 0114 / 0115 / 0116 / 0118
0113**

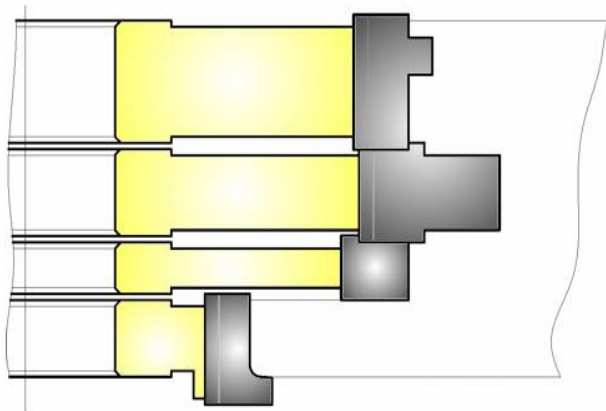

**CONJUNTO LIMPIEZA LIMPIEZA HOJAS
PERFILES REF: 0011 / 0118 / 0114 / 0015 / 0116**

EN EL PRECIO NO ESTAN INCLUIDOS LOS HUSILLOS PORTA HERRAMIENTAS

**KÖMMERLING®**

PVC

CONJUNTO FRESAS RETESTAR
PERFILES REF : 0121 / 0122 / 0125 / 0123

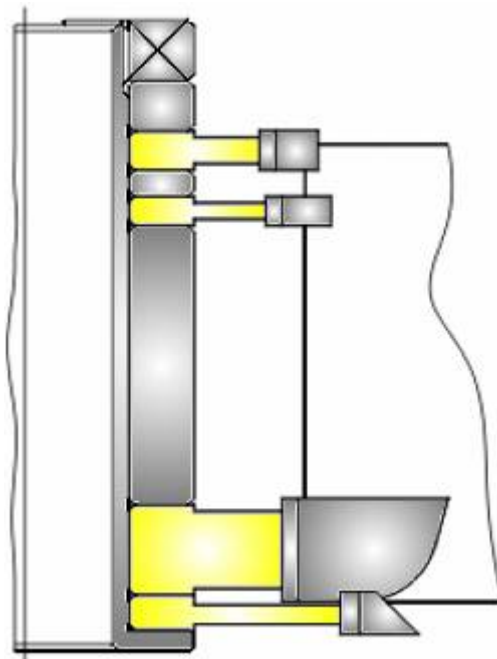

CONJUNTO FRESAS RETESTAR
PERFIL REF : POSTE 2442 CON HOJA

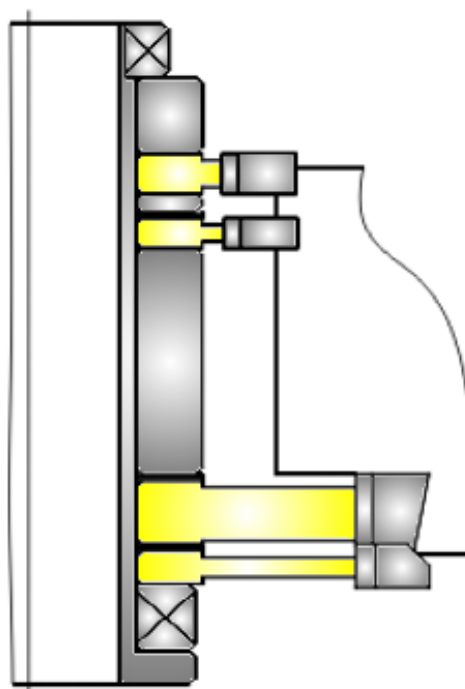

EN EL PRECIO NO ESTAN INCLUIDOS LOS HUSILLOS PORTA HERRAMIENTAS

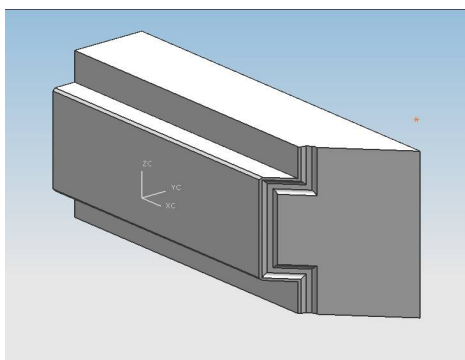

**CONTRAFORMA SOLDAR MARCOS
PERFILES REF: 0001 / 0102**

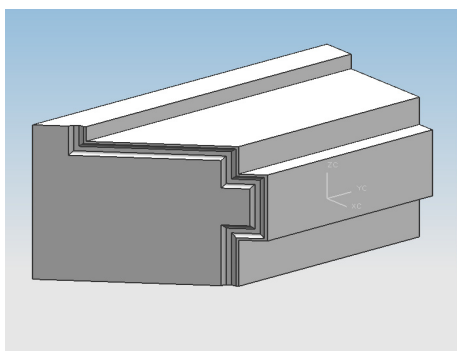

**CONTRAFORMA SOLDAR MARCO SOLAPE
PERFILES REF: 0004**

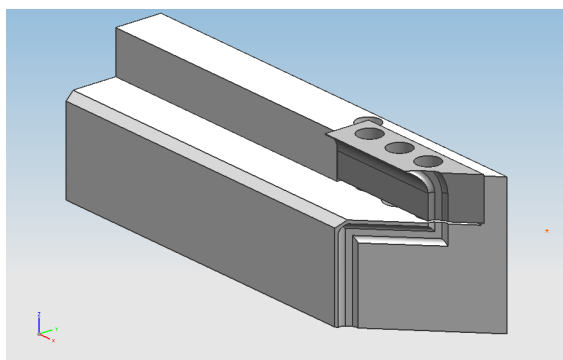

**CONTRAFORMA SOLDAR MARCO SOLAPE
PERFILES REF: 0105**

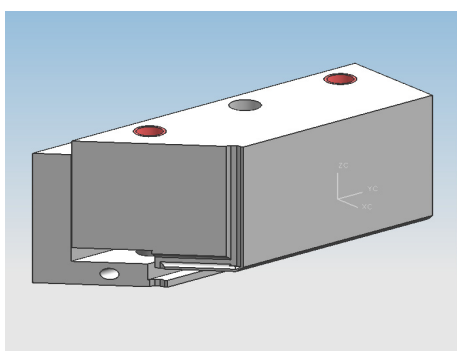

**CONTRAFORMA SOLDAR MARCO SOLAPE
PERFILES REF: 0004
CON MUELLES**

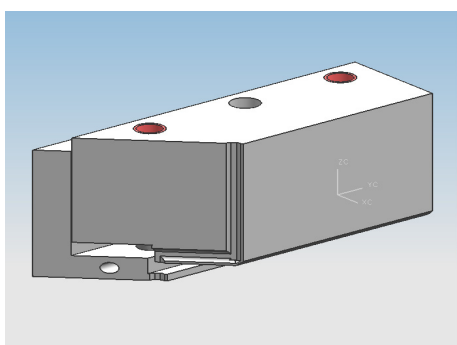

**CONTRAFORMA SOLDAR MARCO SOLAPE
PERFILES REF: 0105
CON MUELLES**

EN EL PRECIO NO ESTAN INCLUIDAS LAS PIEZAS DE SUJECION DE LAS MAQUINAS



**CONTRAFORMA SOLDAR HOJAS
PERFILES REF: 0113
PERFIL CON JUNTA DE GOMA**

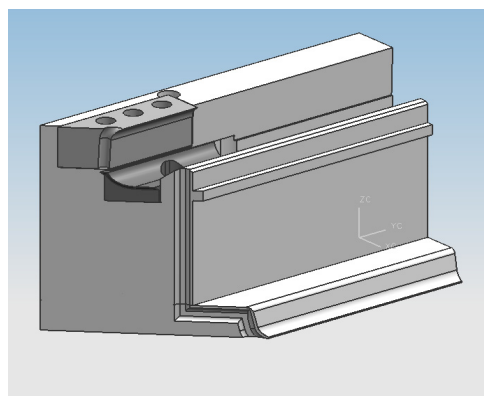

**CONTRAFORMA SOLDAR HOJAS
PERFILES REF: 0011 / 0114 / 0115 / 0116 / 0118
PERFIL CON JUNTA DE GOMA**

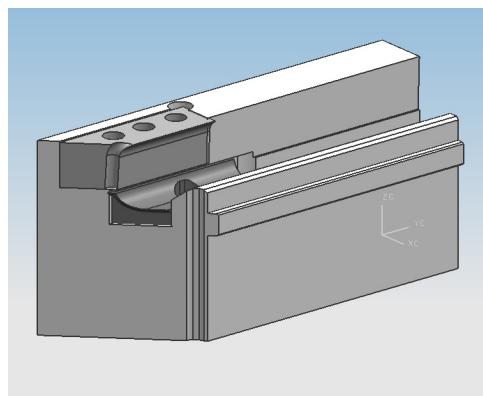

**CONTRAFORMA SOLDAR HOJAS
PERFILES REF: 0011 / 0113 / 0114 / 0115 / 0116 / 0113
PERFIL CON JUNTA DE GOMA**

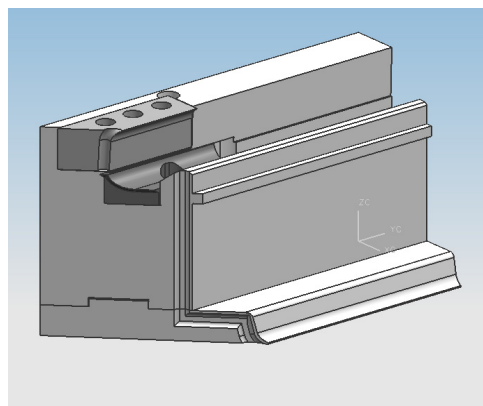

EN EL PRECIO NO ESTAN INCLUIDAS LAS PIEZAS DE SUJECION DE LAS MAQUINAS

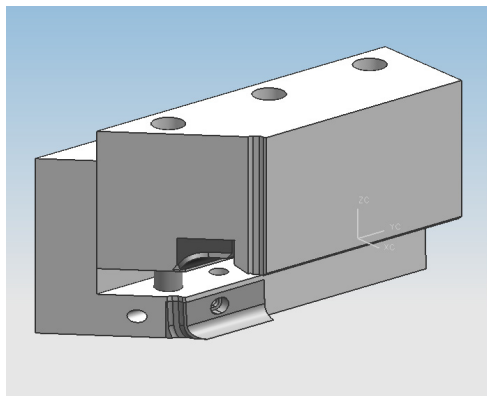

CONTRAFORMA SOLDAR HOJAS
PERFILES REF: 0011 / 0114 / 0115 / 0116 / 0118
CON MUELLES
PERFIL CON JUNTA DE GOMA

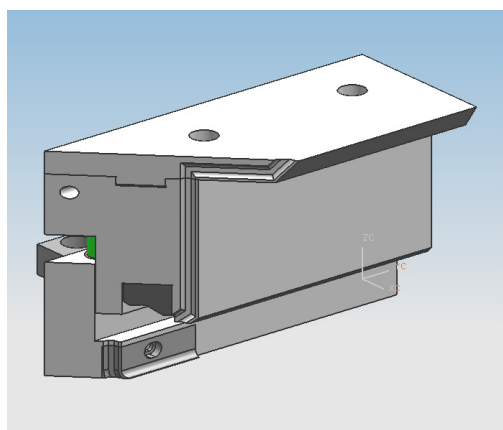

CONTRAFORMA SOLDAR HOJAS
PERFILES REF: 0011 / 0114 / 0115 / 0116 / 0118 / 0113
CON MUELLES
PERFIL CON JUNTA DE GOMA

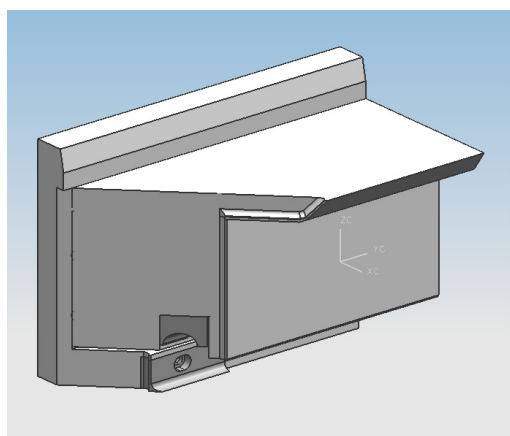

CONTRAFORMA SOLDAR HOJAS
PERFILES REF: 0113
CON MUELLES
PERFIL CON JUNTA DE GOMA

EN EL PRECIO NO ESTAN INCLUIDAS LAS PIEZAS DE SUJECION DE LAS MAQUINAS

**KÖMMERLING®**

PVC

**CONTRAFORMA SOLDAR HOJA
ENVOLVENTES
PERFIL REF. 0113**

**SUPLEMENTO PARA CONTRAFORMA
ENVOLVENTES
PERFIL REF. 0011 - 0118**

**SUPLEMENTO PARA CONTRAFORMA
ENVOLVENTES
PERFIL REF. 0016**

**CUCHILLAS CORTAR SOLDAURA INTERIOR
DE LA HOJA
PERFIL REF. 0113**

**CUCHILLAS CORTAR SOLDAURA INTERIOR
DE LA HOJA
PERFIL 0011 / 0114**

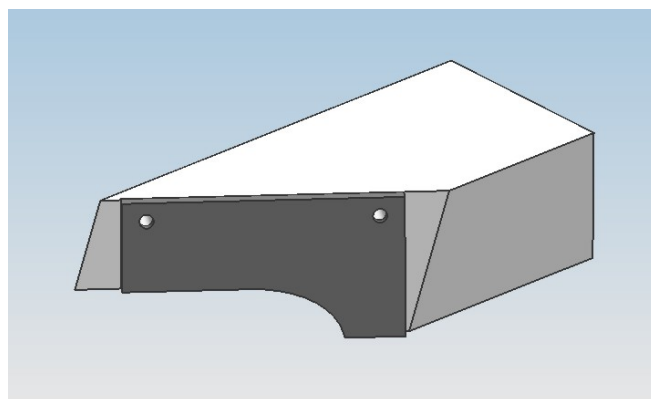
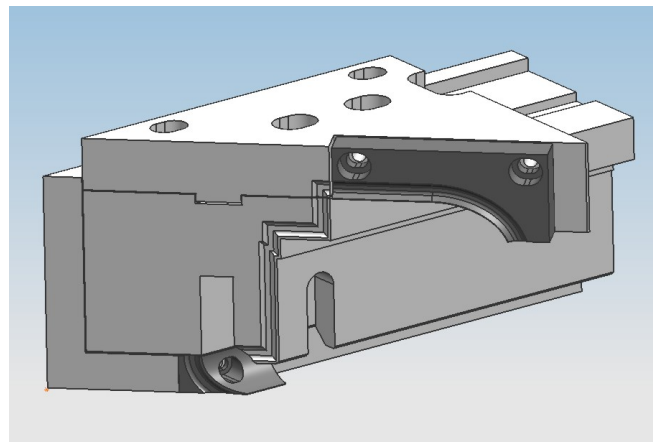

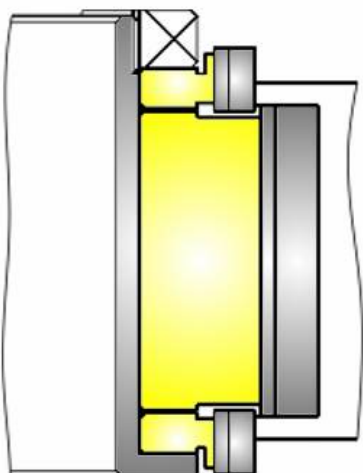

CONJUNTO LIMPIEZA MARCO S 3000
PERFIL : 1400 / 1401 /1501 / 1403

SI PONEMOS FRESA RECTA NO PONER ESTA

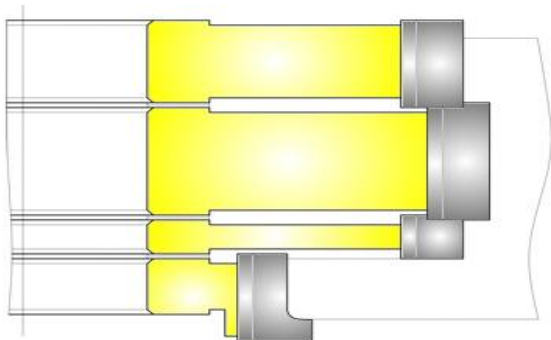

CONJUNTO FRESA LIMPIEZA MARCO RENOVACION
PERFILE : 1594

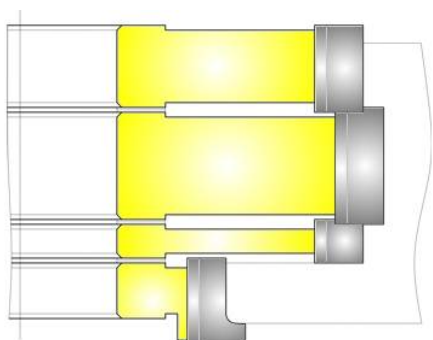

CONJUNTO FRESA LIMPIEZA MARCO RENOVACION
PERFILE : 1501

EN EL PRECIO NO ESTAN INCLUIDOS LOS HUSILLOS PORTA HERRAMIENTAS

**KÖMMERLING®**

CONJUNTO LIMPIEZA HOJAS
PERFILES REF: 1410 / 1411 / 1414 / 1415 / 1416
1418 / 1413

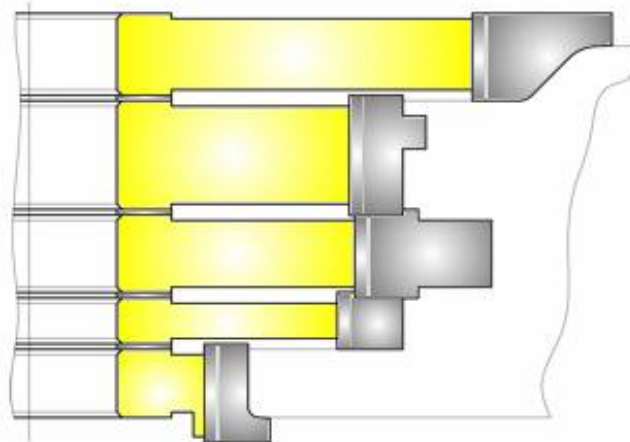

CONJUNTO LIMPIEZA HOJAS
PERFILES REF: 0011 / 0118 / 0114 / 0015 / 0116

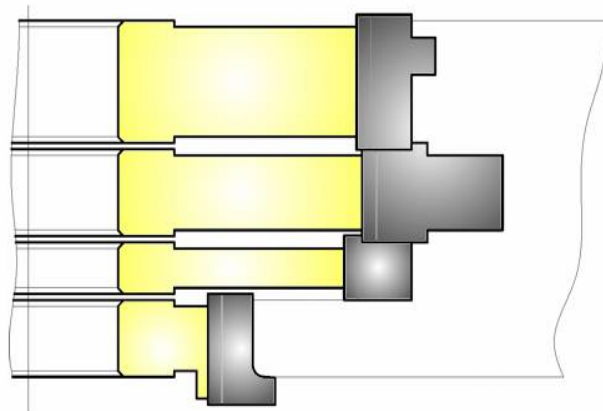

EN EL PRECIO NO ESTAN INCLUIDOS LOS HUSILLOS PORTA HERRAMIENTAS

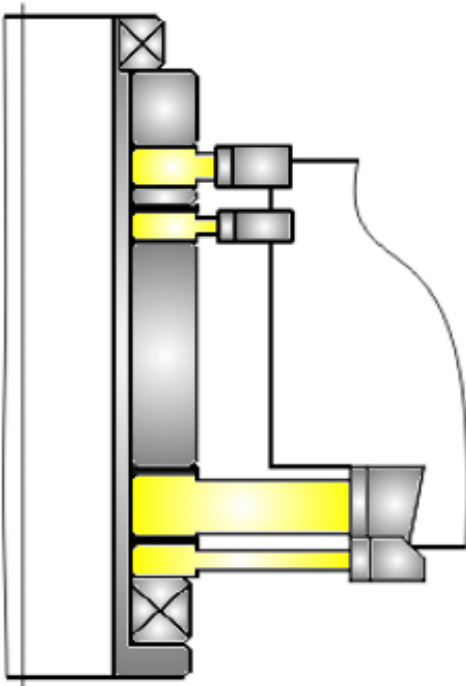

CONJUNTO FRESAS RETESTAR
PERFIL REF : 1422 / 1423

EN EL PRECIO NO ESTAN INCLUIDOS LOS HUSILLOS PORTA HERRAMIENTAS



KÖMMERLING®

**CONTRAFORMA SOLDAR MARCOS
PERFILES REF: 1400 / 1401 / 1402 / 1403**

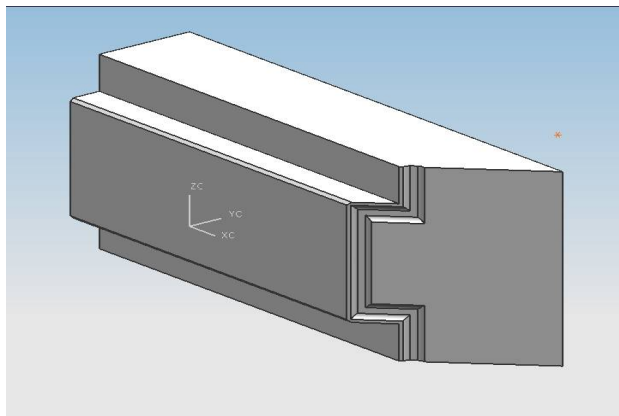

**CONTRAFORMA SOLDAR MARCO RENOVACION
PERFILES REF: 1594**

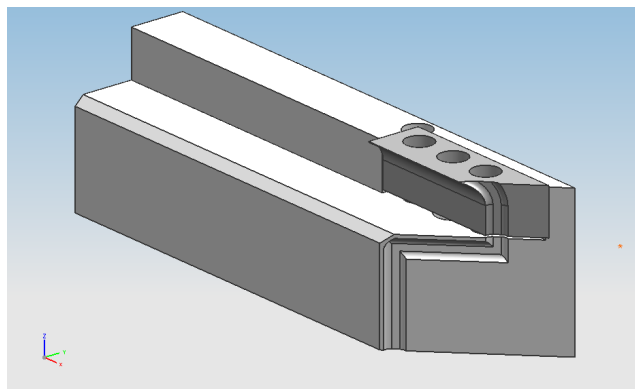

**CONTRAFORMA SOLDAR MARCO RENOVACION
PERFILES REF: 1501**

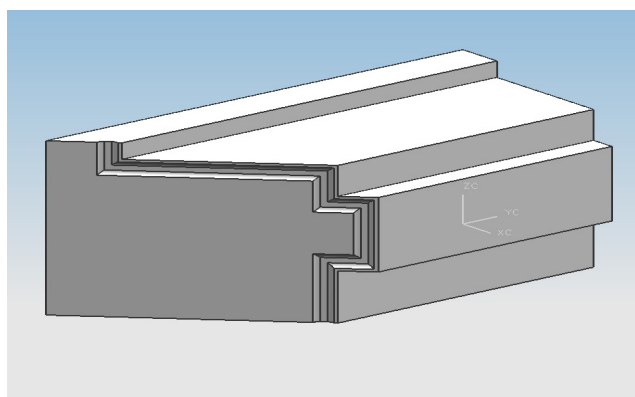

EN EL PRECIO NO ESTAN INCLUIDAS LAS PIEZAS DE SUJECION DE LAS MAQUINAS

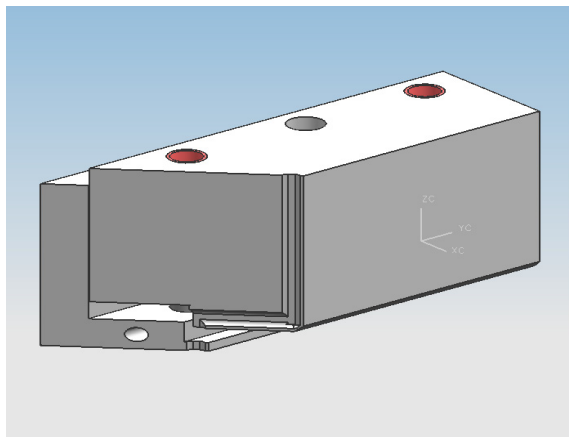

CONTRAFORMA SOLDAR MARCO RENOVACION
PERFILES REF: 1594
CON MUELLES

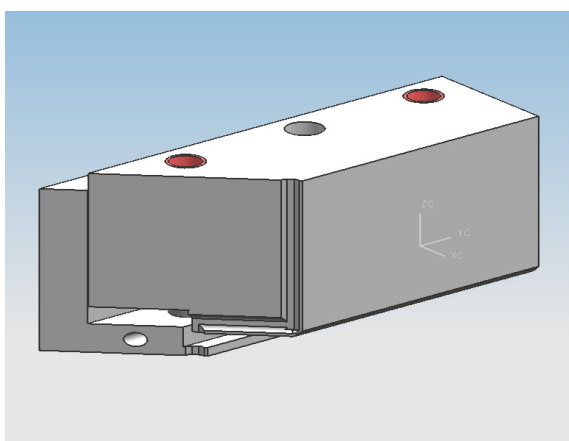

CONTRAFORMA SOLDAR MARCO RENOVACION
PERFILES REF: 1501
CON MUELLES

EN EL PRECIO NO ESTAN INCLUIDAS LAS PIEZAS DE SUJECION DE LAS MAQUINAS

**KÖMMERLING®**

CONTRAFORMA SOLDAR HOJAS
PERFILES REF: 1410 / 1411 / 1414 / 1415 / 1416 / 1418
PERFIL CON JUNTA DE GOMA

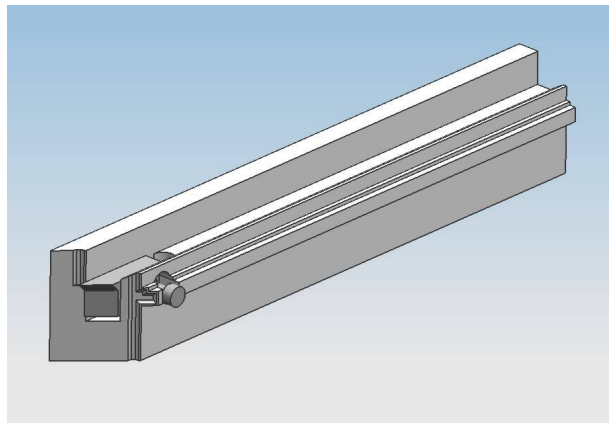

CONTRAFORMA SOLDAR HOJAS
PERFILES REF1410 / 1411 / 1414 / 1415 / 1416 / 1418
1413
PERFIL CON JUNTA DE GOMA

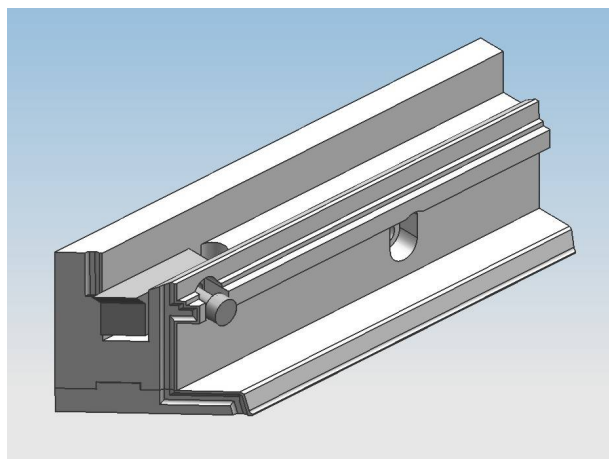

EN EL PRECIO NO ESTAN INCLUIDAS LAS PIEZAS DE SUJECION DE LAS MAQUINAS



KÖMMERLING®

PVC

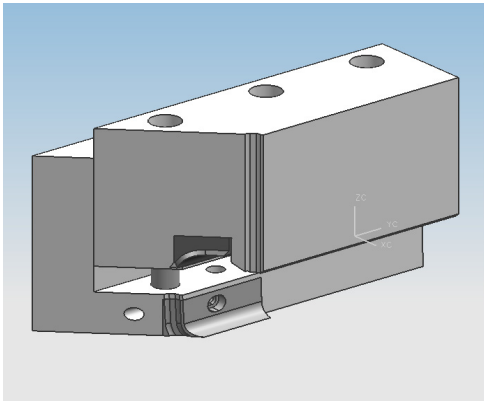

CONTRAFORMA SOLDAR HOJAS
PERFILES REF: 1410 / 1411 / 1414 / 1415 / 1416 / 1418
CON MUELLES
PERFIL CON JUNTA DE GOMA

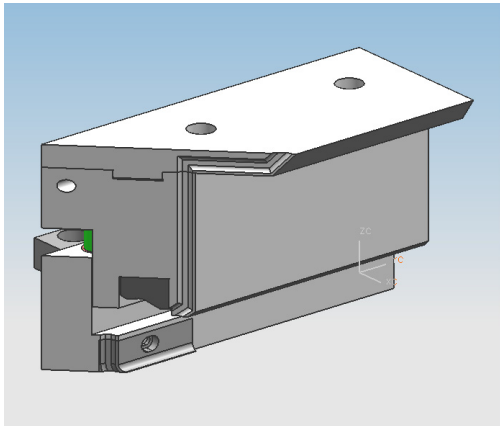

CONTRAFORMA SOLDAR HOJAS
PERFILES REF: 1410 / 1411 / 1414 / 1415 / 1416 / 1418
1413
CON MUELLES
PERFIL CON JUNTA DE GOMA

EN EL PRECIO NO ESTAN INCLUIDAS LAS PIEZAS DE SUJECION DE LAS MAQUINAS

**KÖMMERLING®**

PVC

CONTRAFORMA SOLDAR HOJAS
PERFILES REF: 6121 / 6123
PERFIL CON JUNTA DE GOMA

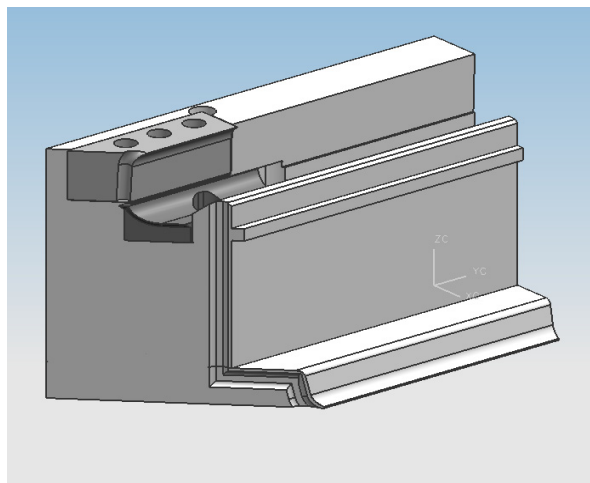

CONTRAFORMA SOLDAR HOJA
PERFIL: 6124BATIENTE FRANCES
PERFIL CON JUNTA DE GOMA

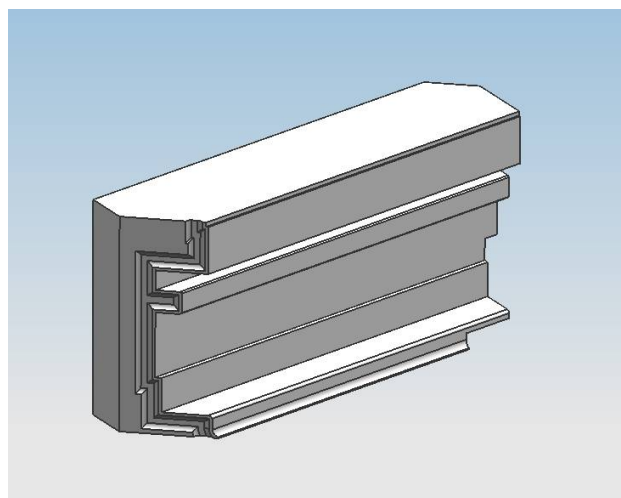

EN EL PRECIO NO ESTAN INCLUIDAS LAS PIEZAS DE SUJECION DE LAS MAQUINAS

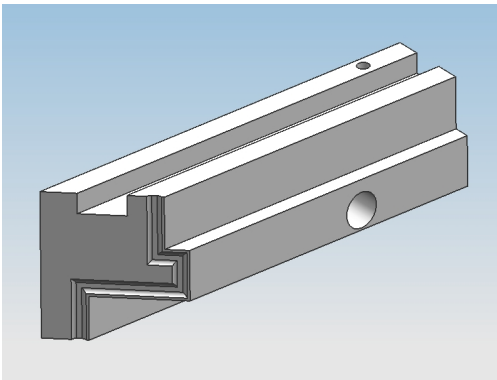

CONTRAFORMA BASE
PERFIL : 0318

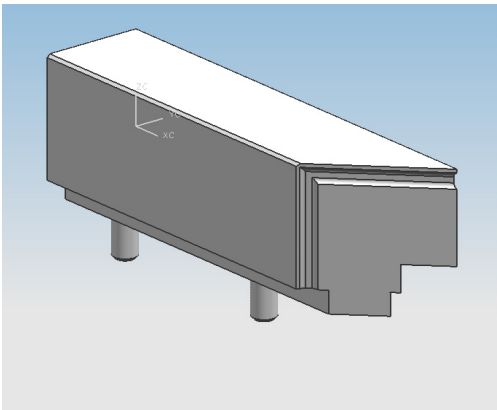

CONTRAFORMA SUPLEMENTO
PERFIL : 0321

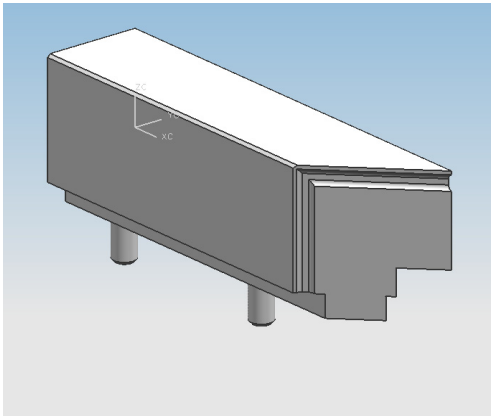

CONTRAFORMA SUPLEMENTO
PERFIL : 0322

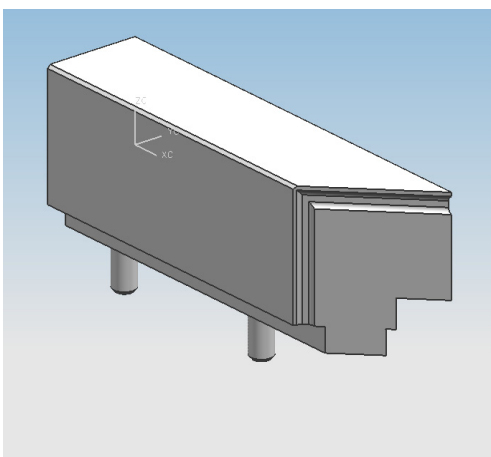

CONTRAFORMA SUPLEMENTO
PERFIL : 0324

EN EL PRECIO NO ESTAN INCLUIDAS LAS PIEZAS DE SUJECION DE LAS MAQUINAS

PVC



**CONJUNTO LIMPIEZA HOJA CORREDERA
PERFILES 6040 - 6041**

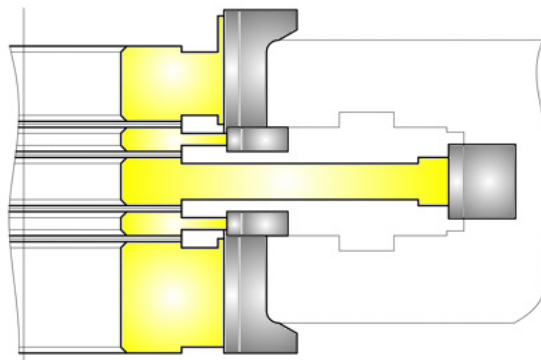

**CONJUNTO LIMPIEZA MARCO CORREDERA
PERFILES 6050 - 6052**

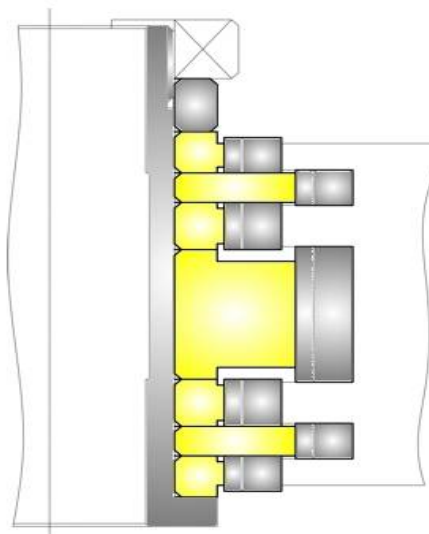

**FRESA LIMPIEZA MARCO CON SOLAPE
PERFIL 6051**

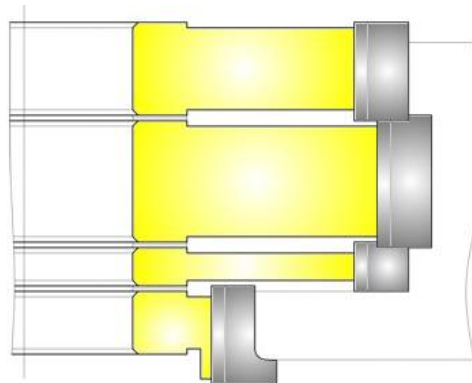

**FRESA LIMPIEZA MARCO CON SOLAPE
PERFIL 6053**

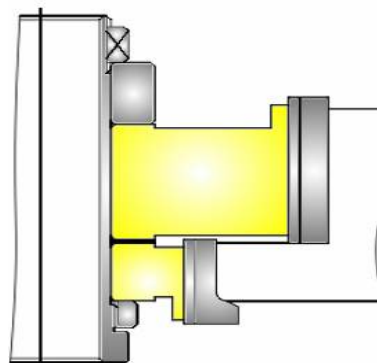

EN EL PRECIO NO ESTAN INCLUIDOS LOS HUSILLOS PORTA HERRAMIENTAS

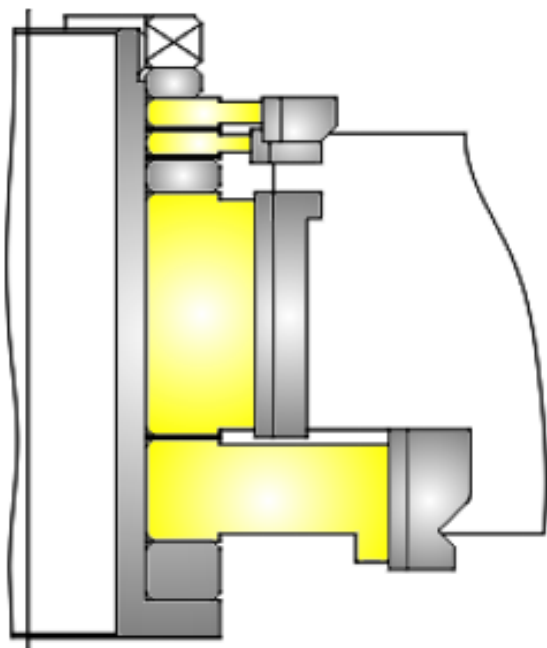

CONJUNTO RETESTAR CORREDERA TRAVESAÑO
PERFILES 6040

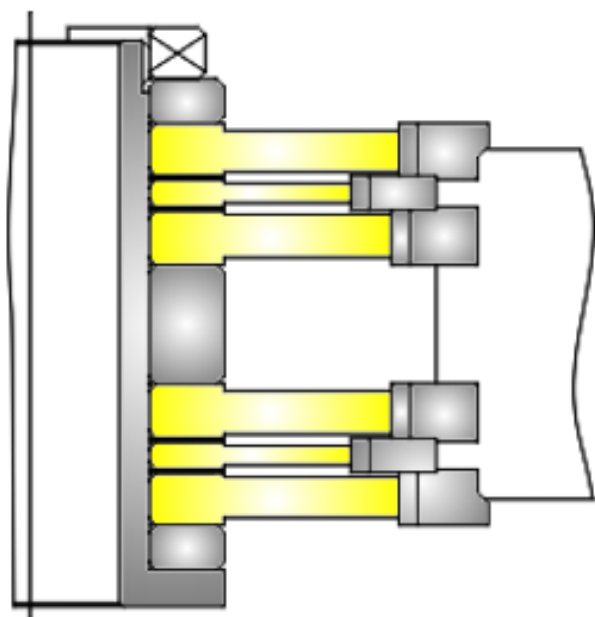

CONJUNTO RETESTAR CORREDERA MARCO
PERFILES 6052

EN EL PRECIO NO ESTAN INCLUIDOS LOS HUSILLOS PORTA HERRAMIENTAS



CONTRA SOLDAR MARCO
PERFILES : 6050 - 6052

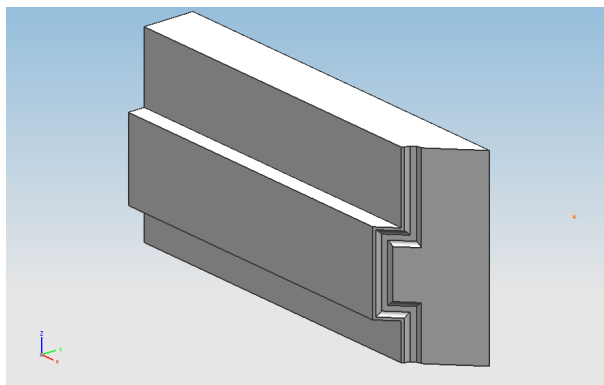

CONTRA SOLDAR MARCO CON SOLAPE
PERFIL : 6051

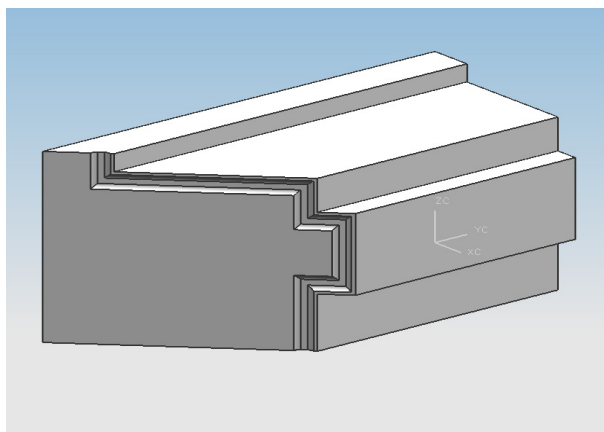

CONTRA SOLDAR MIXTA
MARCOS + MARCO CON SOLAPE
PERFILES : 6050 - 6052 + 6051 PLETINA

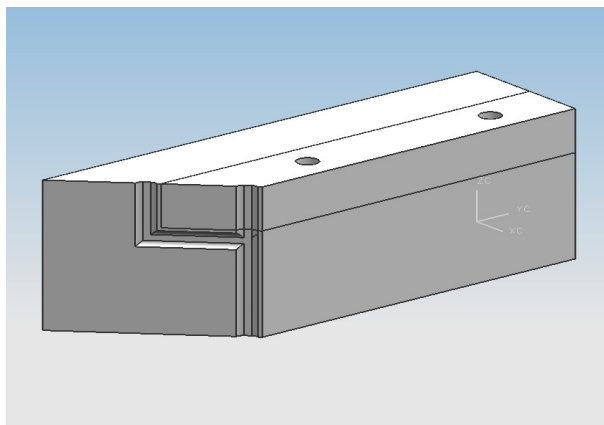

CONTRA SOLDAR HOJA
PERFILES : 6040 - 6041

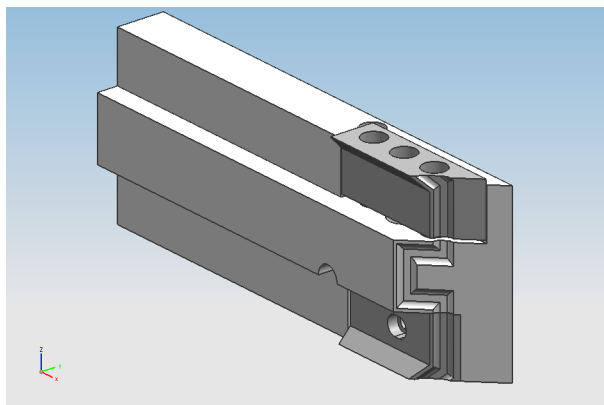

EN EL PRECIO NO ESTAN INCLUIDAS LAS PIEZAS DE SUJECION DE LAS MAQUINAS

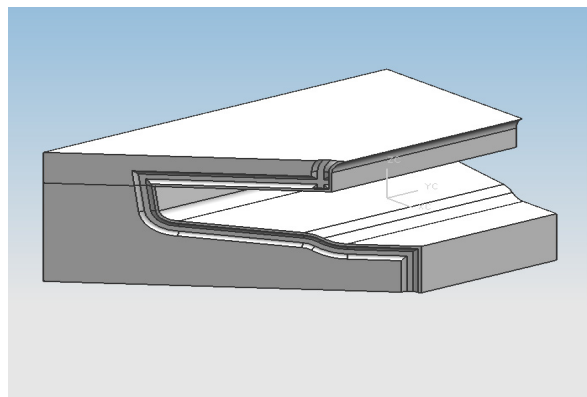

CONTRA SOLDAR FRAILERO
PERFILES : F4334

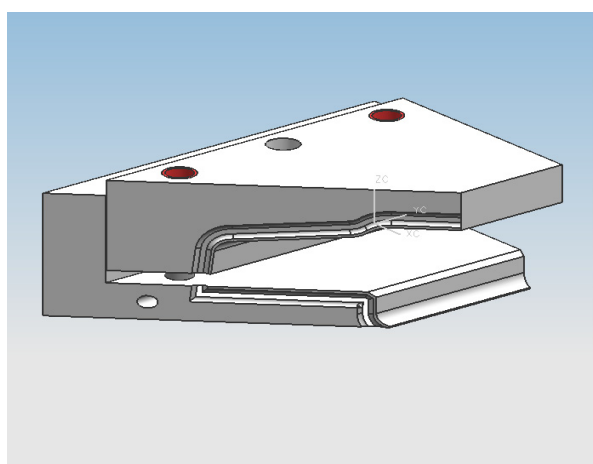

CONTRAFORMA SOLDAR FRAILERO
PERFIL REF : 4334
CON MUELLES

EN EL PRECIO NO ESTAN INCLUIDAS LAS PIEZAS DE SUJECION DE LAS MAQUINAS

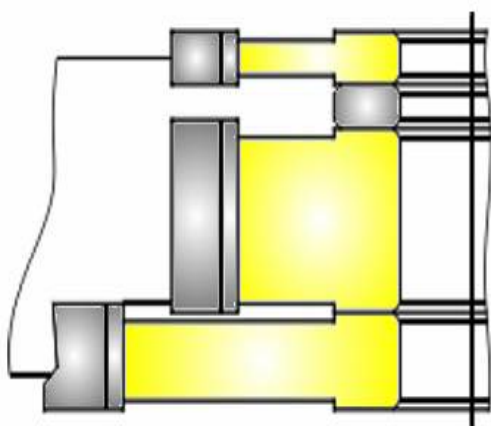

CONJUNTO RETESTAR TRAVESAÑO FRAILERO
PERFILES : F4318

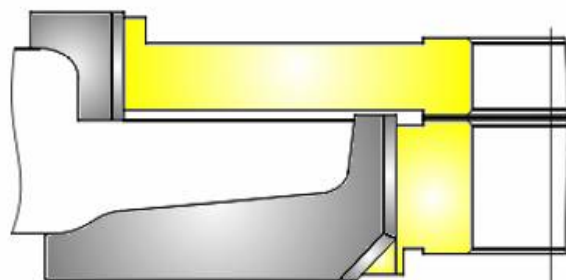

CONJUNTO LIMPIEZA FRAILERO
PERFILES : F4334

EN EL PRECIO NO ESTAN INCLUIDOS LOS HUSILLOS PORTA HERRAMIENTAS

**KÖMMERLING®**

**CONJUNTO FRESAS LIMPIEZA
PERFIL REF: 2420 HOJA CORREDERA ELEVADORA**

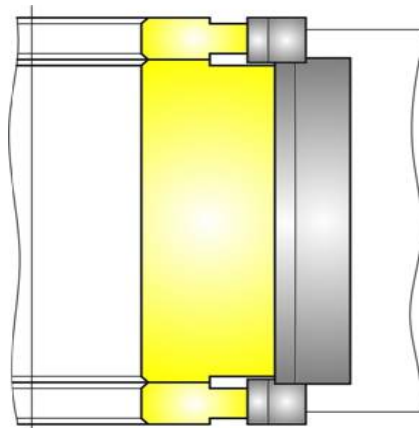

**CONJUNTO FRESAS RETESTAR TRAVESAÑO
PERFIL REF: 2422 CORREDERA ELEVADORA**

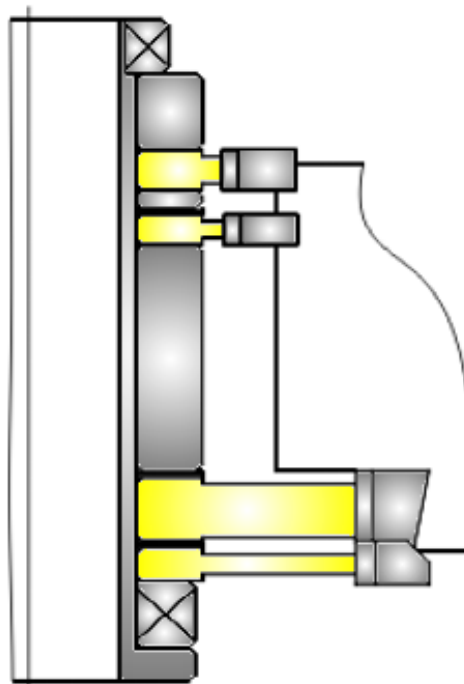

EN EL PRECIO NO ESTAN INCLUIDOS LOS HUSILLOS PORTA HERRAMIENTAS



KÖMMERLING®

PVC

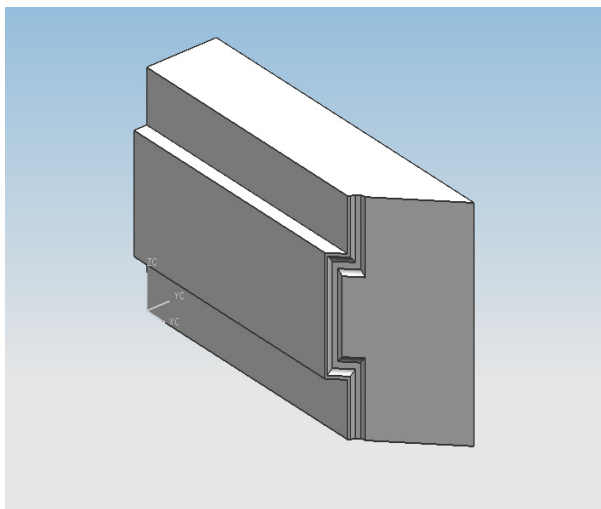

**CONTRAFORMA SOLDAR
PERFILES REF: 2420**

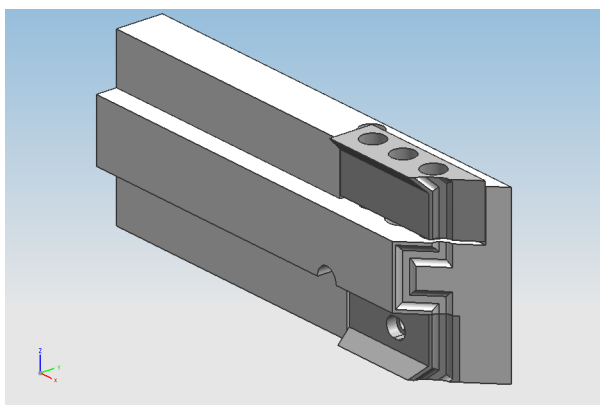

**CONTRA SOLDAR HOJA
PERFILES : 2420
CON CUCHILLA AJUSTABLE**

EN EL PRECIO NO ESTAN INCLUIDAS LAS PIEZAS DE SUJECION DE LAS MAQUINAS

**KÖMMERLING®**

PVC

CONJUNTO FRESAS LIMPIEZA
PERFIL REF: 1396 HOJA CORREDERA

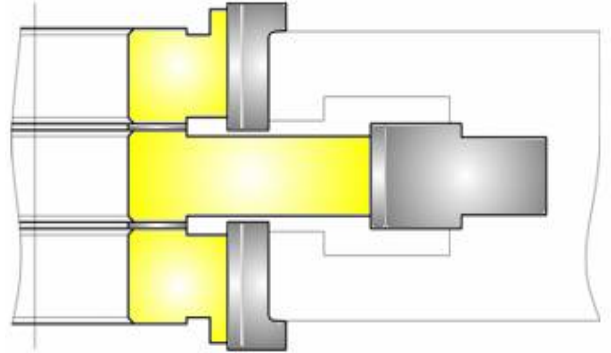

CONJUNTO FRESAS LIMPIEZA MARCO 1397 ES EL MISMO DE LA SERIE EURODUR

EN EL PRECIO NO ESTAN INCLUIDOS LOS HUSILLOS PORTA HERRAMIENTAS



KÖMMERLING®

PVC

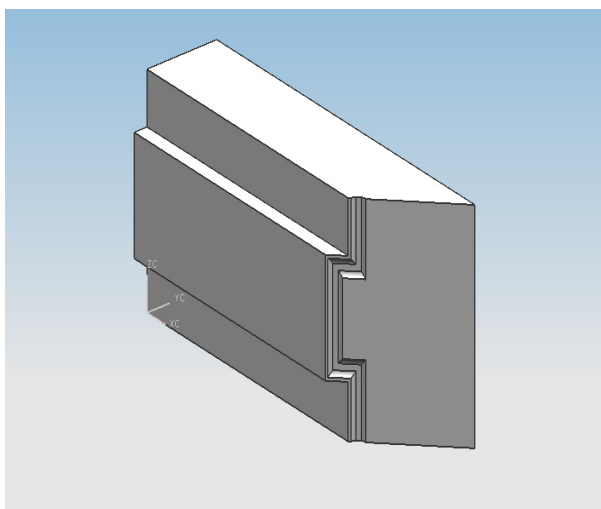

CONTRAFORMA SOLDAR MARCO
PERFIL REF: 1397

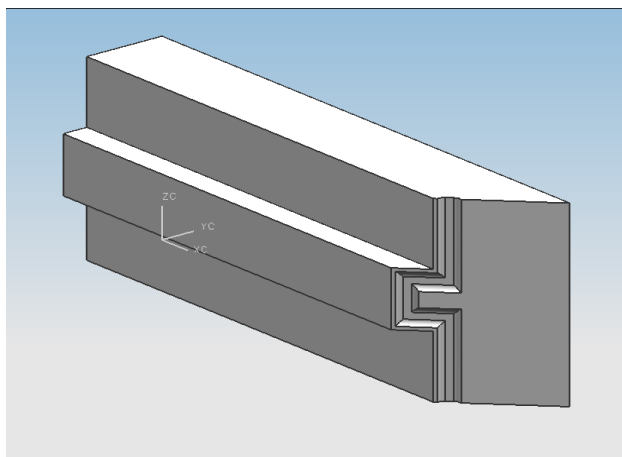

CONTRAFORMA SOLDAR HOJA
PERFILES REF: 1396

EN EL PRECIO NO ESTAN INCLUIDAS LAS PIEZAS DE SUJECION DE LAS MAQUINAS

**KÖMMERLING®**

**CONJUNTO FRESAS LIMPIEZA HOJA
PERFIL REF: 1942**

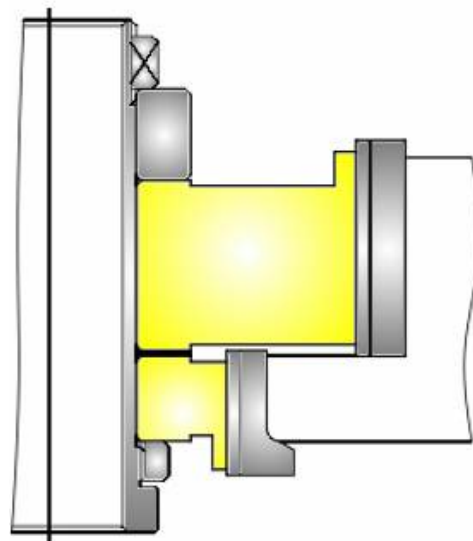

**CONJUNTO FRESAS LIMPIEZA MARCO RENOVACION
PERFIL REF: 1956**

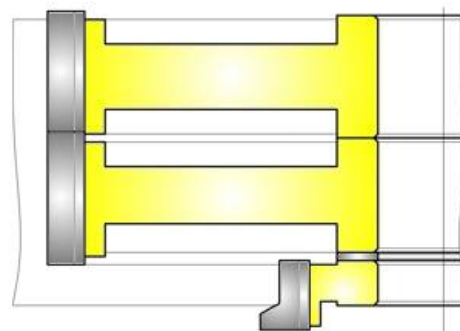

**CONJUNTO LIMPIEZA HOJA
PERFIL 1941**

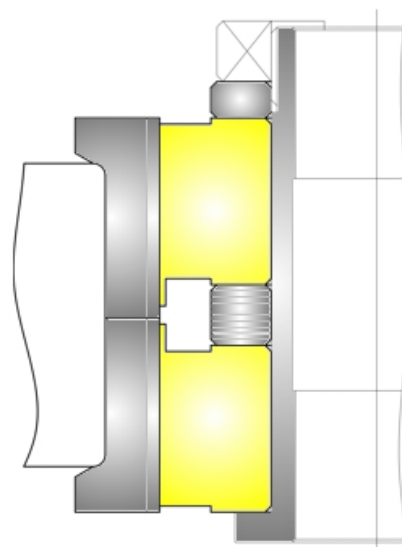

EN EL PRECIO NO ESTAN INCLUIDOS LOS HUSILLOS PORTA HERRAMIENTAS

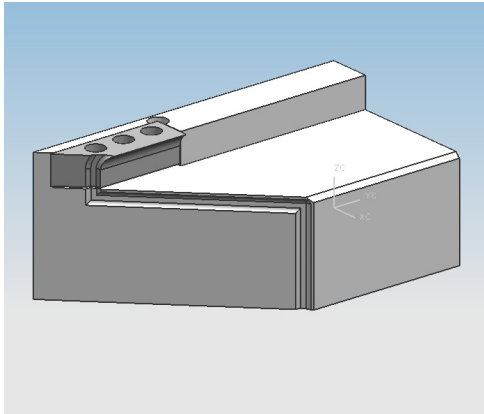

**CONTRAFORMA SOLDAR
PERFIL REF : 1956**

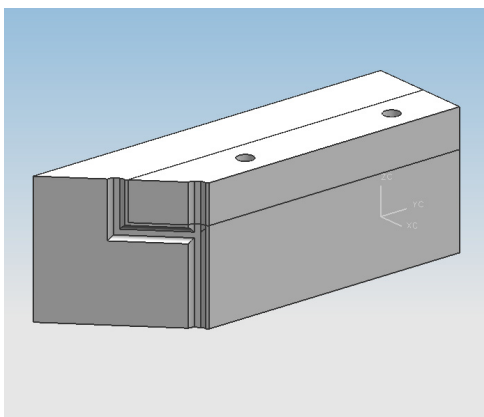

**CONTRAFORMA SOLDAR
PERFIL 1491 / 1942**

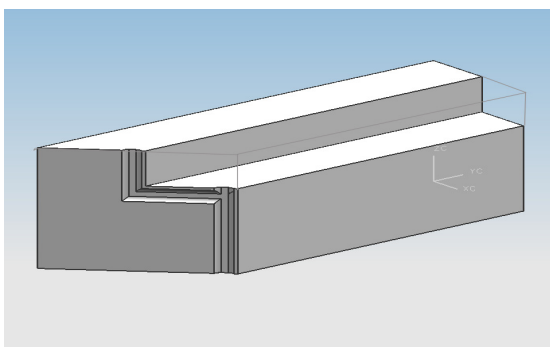

**CONTRAFORMA SOLDAR
PERFILES REF: 1501**

EN EL PRECIO NO ESTAN INCLUIDAS LAS PIEZAS DE SUJECION DE LAS MAQUINAS



KÖMMERLING®

PVC

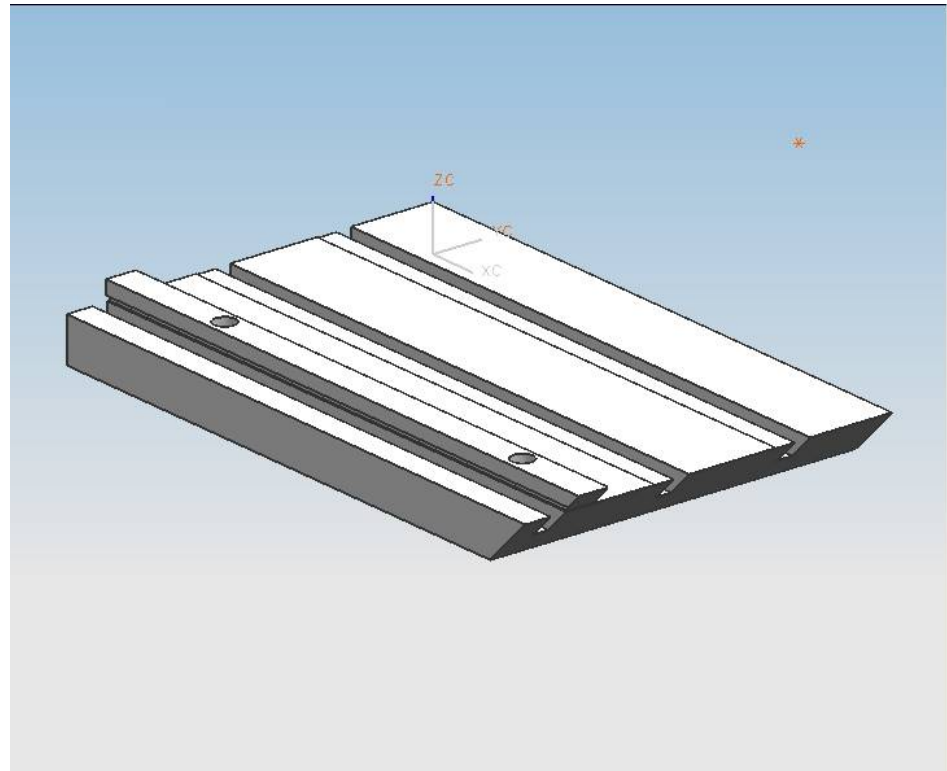

CONTRAFORMA CORTAR JUNQUILLOS

URBAN 2 CABEZALESZ AKS 1200

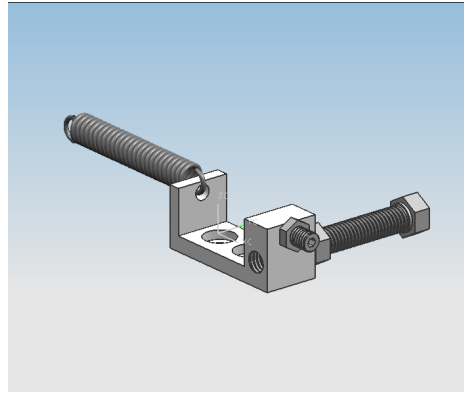

URBAN 4 CABEZALESZ AKS 1400/ETS

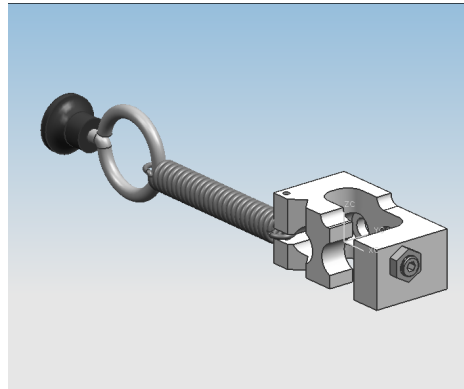

URBAN AKS 1610 4 cabezales

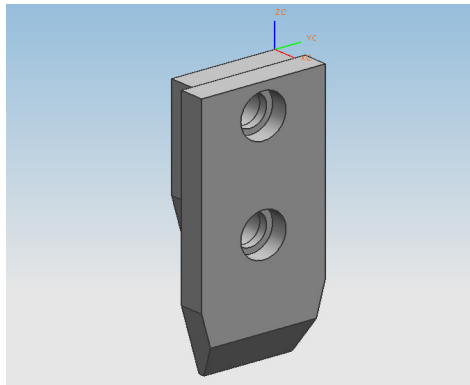

KABAN BB 2030
KABAN BA 2030

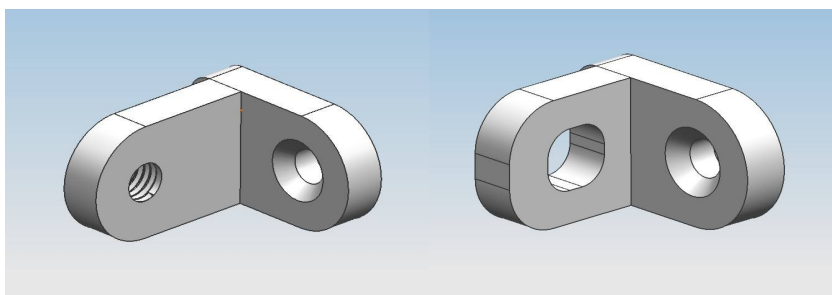

KABAN BA 2020

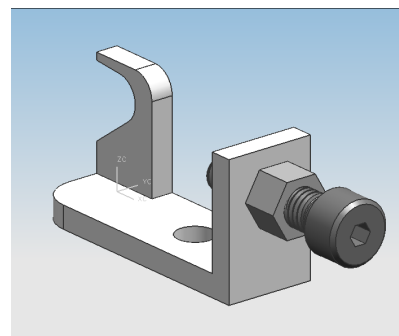

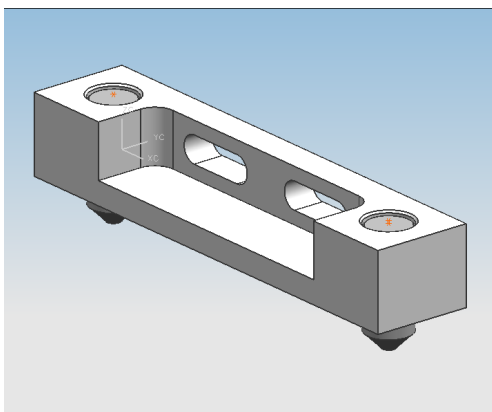

MECAL - MK1 - MK2

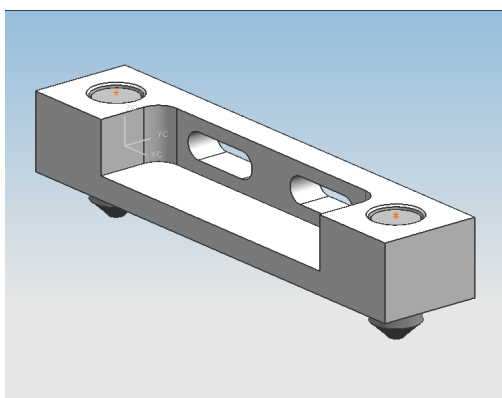
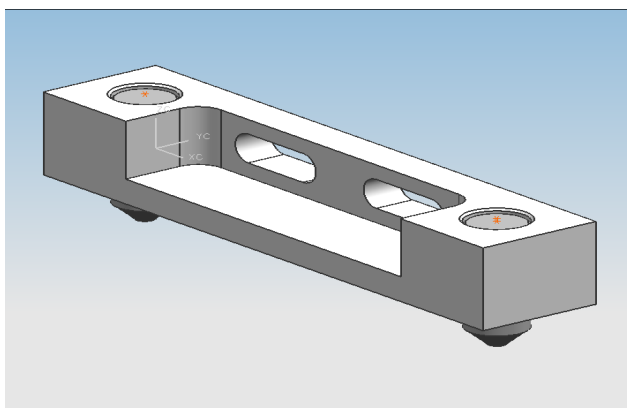
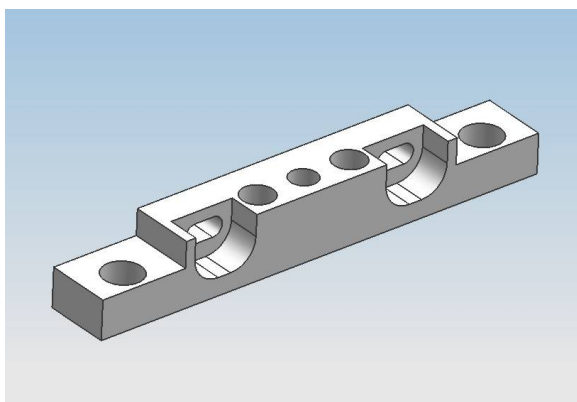
SOENEN HENDRICK CR 802 — MAR 2
PIEZA CORTASOENEN HENDRICK CR 80 CR 802
MAR 2 pieza larga

WEGOMA WSA-4L— H

HOLINGER HMS- E

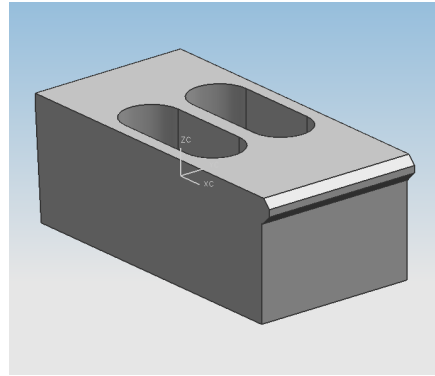

HOLLINGER MSA - 7

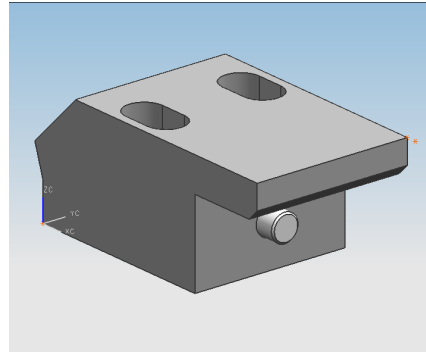

ACTUAL A 312 B90-1 2cabezales
Pieza corta L155 Pieza larga 200

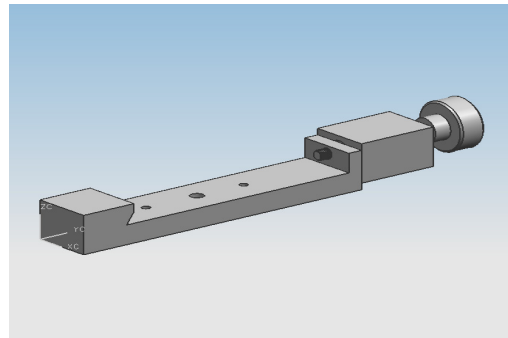

PROFTEQ CUADOS 4 cabezales

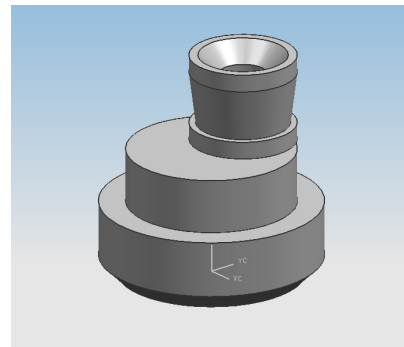

STB - WIN LINE 4cabezales

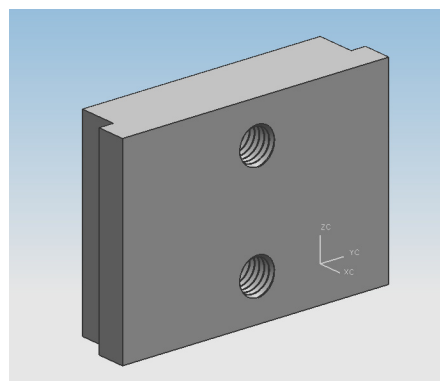

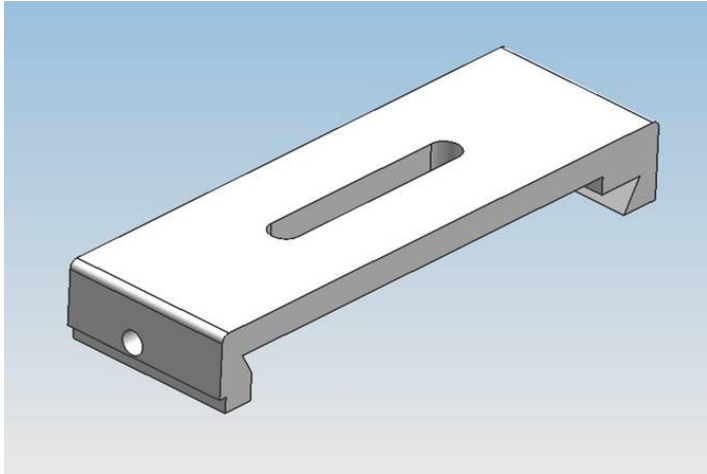

SOENEN HENDRICK Q 4

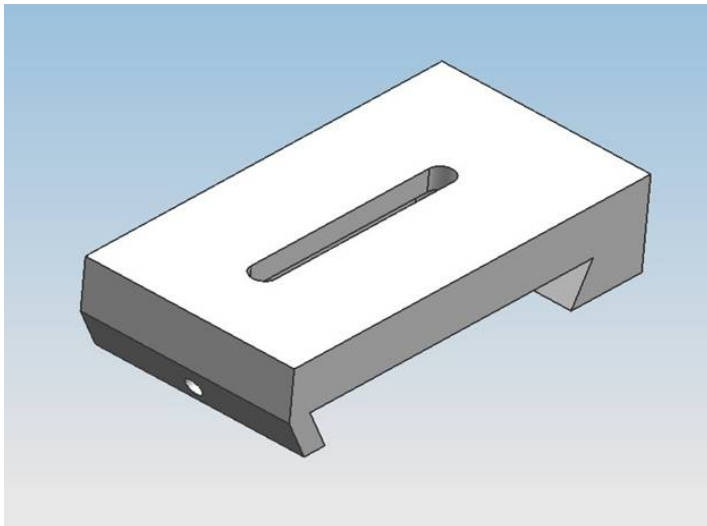

ACTUAL A 312 4 CABEZALES

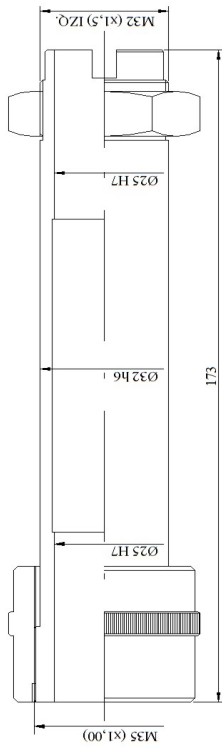

MAQUINA FO MISTRAL
FON JET

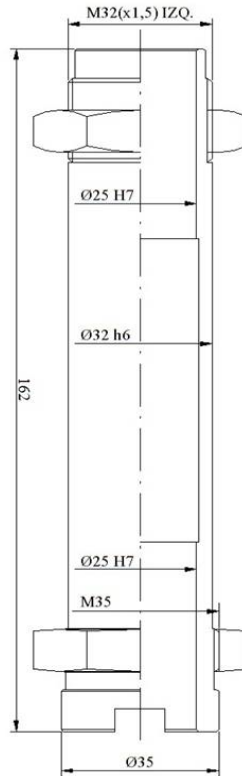

MAQUINA MECAL FR 711
GREENMAQ
ALTECK LIBRA

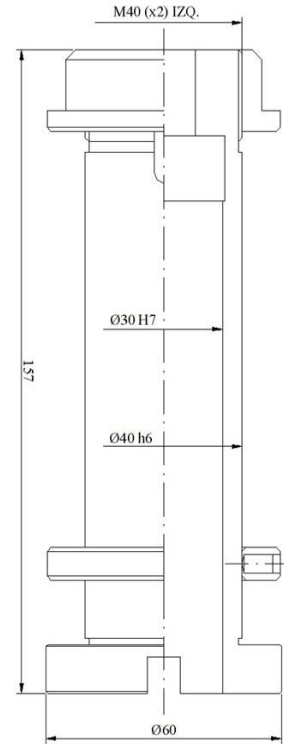

MAQUINA ROTOX SAF 165

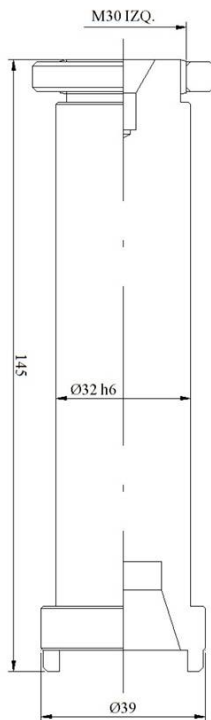

MAQUINA TEKNA TK 641

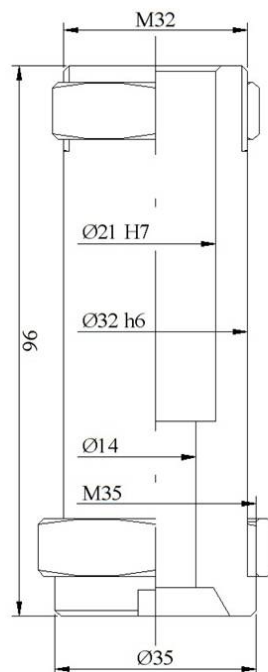

MAQUINA AYUTOR

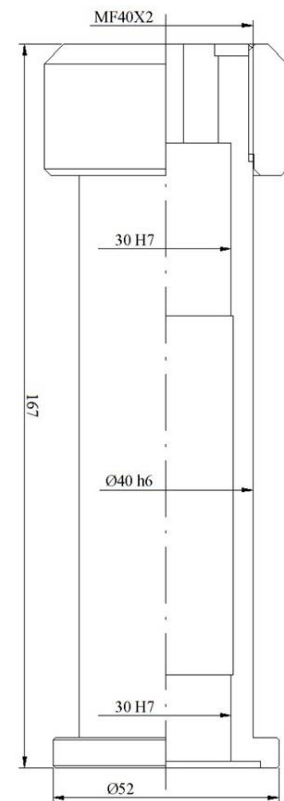

MAQUINA ELUMATEC AF 221

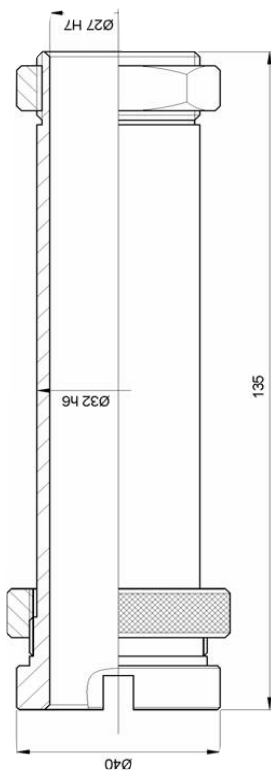

**MAQUINA INTEX 3000
CODMISA C 704**

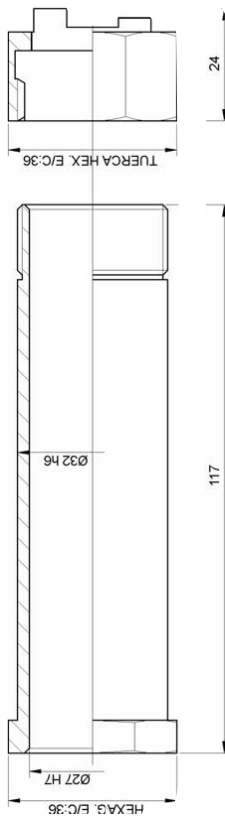

MAQUINA URBAN SVA-21-M7.CRH

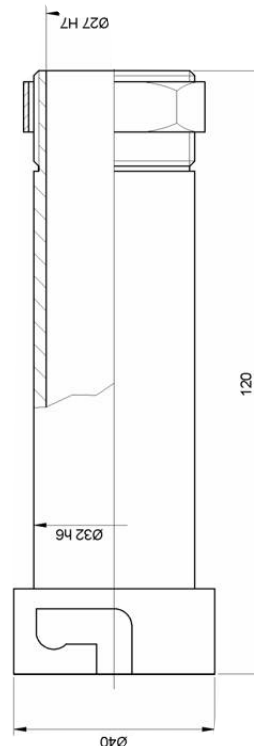

MAQUINA COMALL

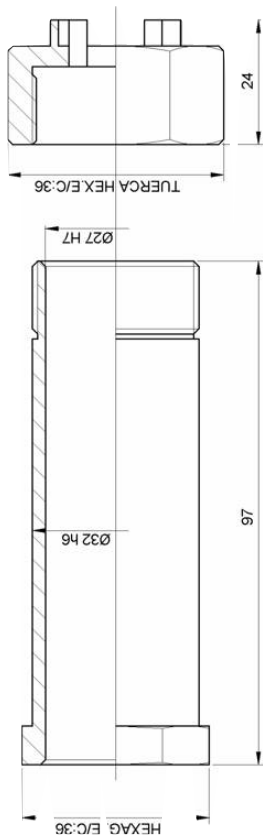

MAQUINA MLA

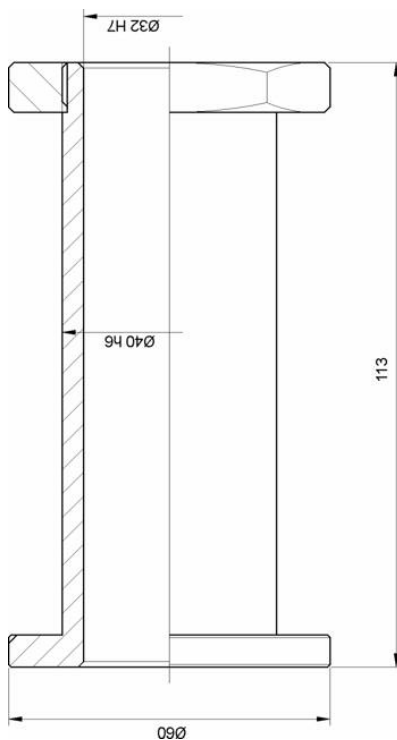

MAQUINA ELUMATEC EV-834

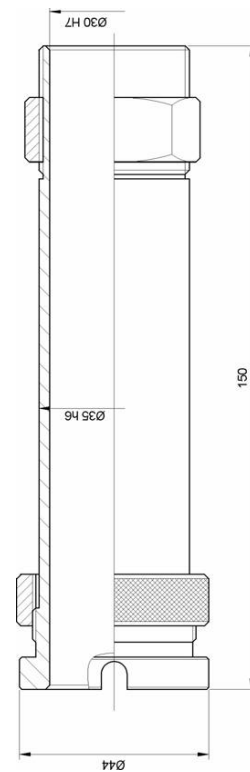

MAQUINA INTEX 3500

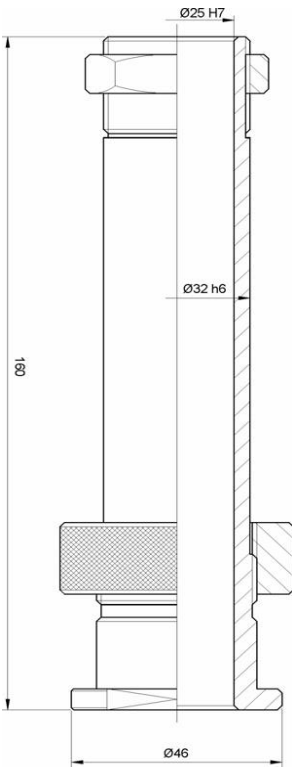

MAQUINA INFISMAL

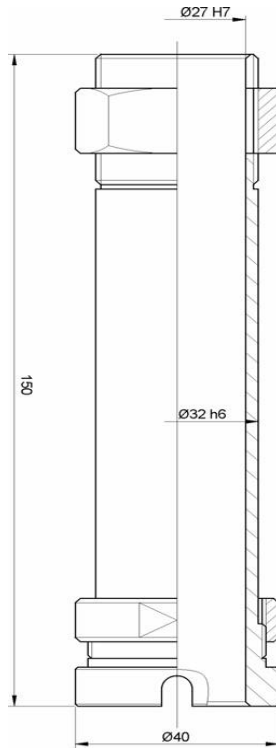

MAQUINA MECAL FR 702

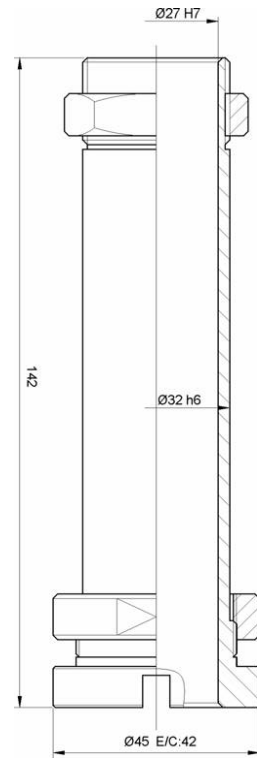

MAQUINA MG RAFRE

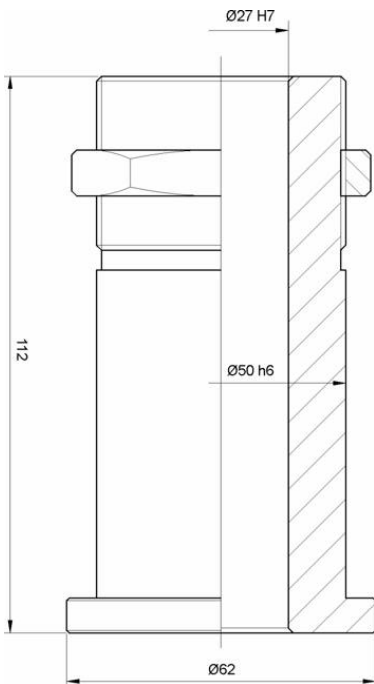

MAQUINA PV.TECNIC
CAJON DE LIMPIEZA

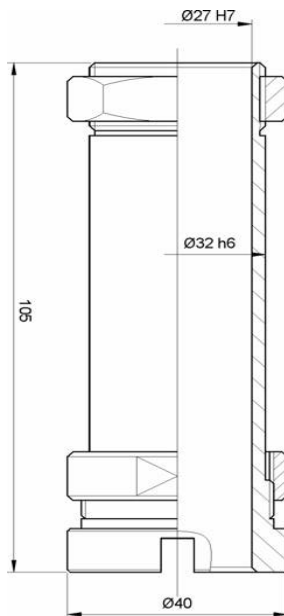

MAQUINA INTEX 2500

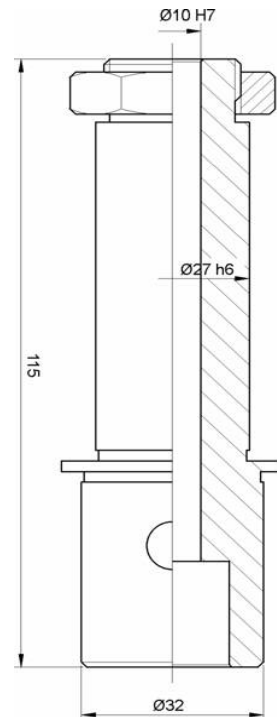

MAQUINA VALLE

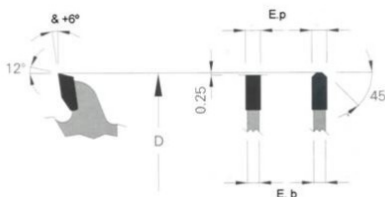

D	d	E.b	E.p	Z	TALADROS	REFERENCIA	PVP	O
200	20	2,2	2,8	64		0055120002006432	B 37	■
250	32	2,6	3,2	80	2/11/63	0055125003208032	B 44	■
275	20	2,6	3,2	72		0055127502007232	B 44	■
300	32	2,6	3,2	72	2/11/63	0055130003207232	B 45	■
300	30	2,6	3,2	96	2/7/42+2/10/60	0055130003209632	B 48	■
300	32	2,6	3,2	96	2/11/63	0055130003209632	B 48	■
300	32	3,0	3,6	96	2/11/63	0055130003209636	C 7	■
330	30	2,6	3,2	102		0055133003010232	C 11	■
350	32	2,6	3,2	84	2/11/63	0055135003208432	C 9	■
350	30	3,0	3,6	108		0055135003010836	C 20	■
350	32	3,0	3,6	108	2/11/63	0055135003210836	C 20	■
400	30	3,2	3,8	96		0055140003009638	C 25	■
420	30	3,2	3,8	96		0055142003009638	C 35	■
450	30	3,2	3,8	108		0055145003010838	C 40	■
450	32	3,2	3,8	108	2/11/63	0055145003210838	C 40	■
500	30	3,8	4,4	120		0055150003012044	C 52	■
500	30	3,8	4,4	160		0055150003016044	E 7	■
550	30	3,8	4,4	140		0055155003014444	E 29	
600	30	3,8	4,4	190		0055160003019044	E 47	
650	40	4,0	5,2	108		0055165004010852	F 2	
650	40	4,4	5,2	180		0055165004018052	E 52	
700	40	4,4	5,2	190		0055170004019052	F 8	
750	40	4,4	5,2	190		0055175004019052	F 16	
760	30	5,0	6,0	72		0055176003007260	F 11	
800	30	4,4	5,2	180		0055180003018052	F 17	
800	40	4,4	5,2	210		0055180004021052	F 27	

KANEFUSA

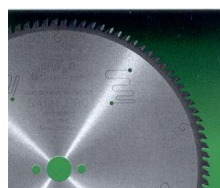

D	d	E.b	E.p	Z	TALADROS	REFERENCIA	PVP	O
250	32	2,4	3,0	80	2/11/63	0059725003008030	C 1	■
300	32	3,0	3,5	96	2/11/63	0059730003209635	C 22	■
350	32	3,0	3,5	108	2/11/63	0059735003210835	C 36	■
400	30	3,0	3,5	120		0059740003012035	C 39	■
450	32	3,4	4,0	144		0059745003214440	E 8	■

Disco para el corte de aluminio, plásticos y PVC.

Dispone de ángulo de corte positivo.

Recomendado para máquinas de corte con avance automático.

Estos discos ofrecen una menor resistencia a la hora de realizar los cortes.

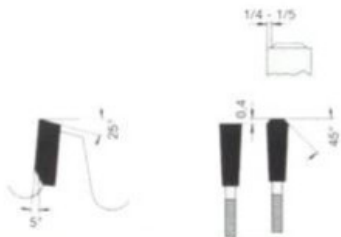

D	d	E.b	E.p	Z	TALADROS	REFERENCIA	PVP	O
150	20	2,0	2,8	42		0055215002004228	B 29	■
175	20	1,6	2,1	68	Junquilladoras	0055217502006821	C 6	■
180	20	2,0	2,8	42		0055218002004228	B 32	■
180	20	2,2	2,8	58	Junquilladoras	0055218002004828	B 42	■
200	20	2,2	3,0	48		0055220002004830	B 29	■
200	32	2,2	2,6	80	Junquilladoras	0055220003208026	B 32	■
200	30/32	1,8	2,2	100	Junquilladoras	0055220003210022	B 50	■
225	32	2,2	2,6	80	Junquilladoras	0055222503206026	B 32	■
250	30	2,6	3,2	60	2/7/42+2/10/60	0055225003006032	B 32	■
250	32	2,6	3,2	60	2 / 11 / 63	0055225003206032	B 32	■
250	32	2,6	3,2	80	2 / 11 / 63	0055225003208032	B 44	■
250	30	2,6	3,2	100		0055225003010032	B 48	■
250	20	1,8	2,2	120	Junquilladoras	0055225002012022	C 10	■
300	30	2,6	3,2	96	2/10/60	0055230003209632	B 52	■
300	32	3,0	3,6	96	2 / 11 / 63	0055230003209636	C 7	■
350	32	3,0	3,6	108	2 / 11 / 63	0055235003210836	C 20	■
380	32	2,8	3,4	102		0055238003210234	C 30	■
380	30	2,8	3,6	110		0055238003011036	C 35	■
400	30	3,2	3,8	96		0055240003009638	C 25	■
400	30	3,2	3,8	120		0055240003012038	C 35	■
450	30	3,2	3,8	96		0055245003009638	C 37	■
450	30	3,2	3,8	108		0055245003010838	C 40	■
500	30	3,2	3,8	120		0055250003012038	C 52	■

DISCOS BISEL 45° PARA MAQUINA CORTAR JUNQUILLOS DE PVC

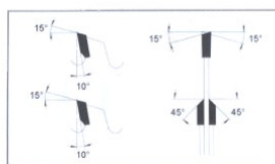

D	d	E.b	E.p	Z	MAQUINA	REFERENCIA	PVP	O
92 R	30	2,5	3,0	24	Rotox	0059209203002430	B 31	■
92 L	30	2,5	3,0	24	Rotox	0059109203002430	B 31	■
95 R	20	1,6	2,1	20	Haffner	0059209502002021	B 14	■
95 L	20	1,6	2,1	20	Haffner	0059109502002021	B 14	■
95 R	32	2,0	2,5	24	Kaban -strongbull	0059209503202425	B 15	■
95 L	32	2,0	2,5	24	Kaban -strongbull	0059109503202425	B 15	■
98 R	32	2,0	3,0	36	Elu	0059209803203630	B 40	■
98 L	32	2,0	3,0	36	Elu	0059109803203630	B 40	■
103 R	32	1,6	2,1	24	Wegoma- Urban	0059210303202421	B 22	■
103 L	32	1,6	2,1	24	Wegoma- Urban	0059110303202421	B 22	■
175 R	32	1,6	2,5	68	Protec	0059217503206825	C 10	■
175 L	32	1,6	2,5	68	Protec	0059117503206825	C 10	■

Disco para corte de aluminio, plásticos y PVC. Con ángulo de corte negativo.
Recomendado tanto para máquinas con avance manual o automático

Estos discos ofrecen una mayor resistencia al corte, sin embargo resisten mejor los posibles accidentes

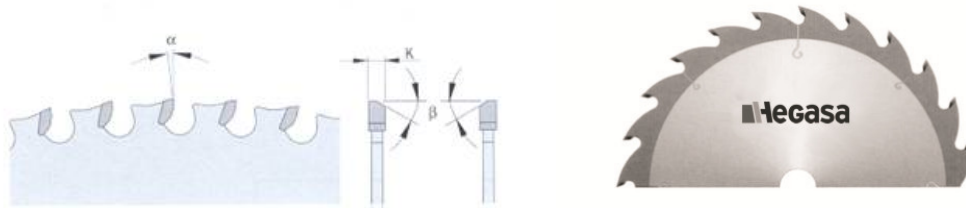

PVC

Ø Sierra	RPM Maximas
190	8.000
200-210-216	6.000
250	5.900
300	4.900
350	4.200

D	d	E.b	E.p	Z	TALADROS	REFERENCIA	PVP	O
150	16	1,6	2,2	30		0059615001603022	A 51	■
160	16	1,6	2,2	30		0059616001603022	A 51	■
170	16	1,6	2,2	32		0059617001903222	B 2	■
180	16	1,6	2,2	36		0059618001603622	B 5	■
190	30	1,8	2,2	38		0059619003004822	B 7	■
200	30	1,8	2,2	40		0059620003004022	B 8	■
210	30	1,8	2,2	54		0059621003005422	B 12	■
216	30	1,8	2,2	54		0059621603005422	B 22	■
230	30	1,8	2,2	44		0059623003004422	B 13	■
250	30	1,8	2,2	54		0059625003005422	B 19	■
300	30	1,8	2,2	60		0059630003006022	B 28	■
300	30	1,8	2,2	80		0059630003008022	B 38	■
350	30	2,0	2,4	80		0059635003008024	B 43	■
355	24,5	2,2	2,6	80		0059635502408026	B 43	■
400	30	2,5	3,0	80		0059640003008030	C6	■

Para corte en “seco” de acero suave e inoxidable, tubos y perfiles de acero, paneles sándwich (tanto en acero como aluminio).

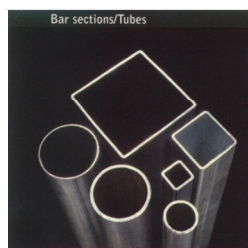
Tener en cuenta las RPM máximas que se indican en la tabla de arriba



DIMENSIONES	TALADROS	STEAN HSS	PVP	STEAN HSS 5% Co	PVP
200 x 2,0 x 32	2/8,5/45 + 2/11/63	0044020003220	B 13	0044120003220	B 21
225 x 2,0 x 32	2/8,5/45 + 2/11/63	0044022503220	B 13	0044122503220	B 23
250 x 2,0 x 32	2/8,5/45+2/12/64+4/9/50	0044025003220	B 16	0044125003220	B 27
250 x 2,0 x 40	2/8,5/45+2/11/63	0044025004020	B 16	0044125004020	B 27
250 x 2,5 x 32	2/8,5/45+2/12/64	0044025003225	B 18	0044125003225	B 28
250 x 2,5 x 40	2/8,5/45 + 2 /12/64	0044025004025	B 18	0044125004025	B 28
275 x 2,5 x 32	2/8,5/45 + 2/12/64	004402753225	B 24	0044127503225	B 36
275 x 2,5 x 40	2/8,5/45 + 2/12/64	0044027504025	B 24	0044127504025	B 36
300 x 2,5 x 32	2/8,5/45 + 2/12/64+ 2/12,5/75	0044030003225	B 33	0044130003225	B 49
300 x 2,5 x 40	2/8,5/55 + 4/12/64	0044030004025	B 33	0044130004025	B 49
315 x 2,5 x 32	2/8,5/45 + 2/12/64+2/12,5/75	0044031503225	B 37	0044131503225	C 1
315 x 2,5 x 40	2/9/55 + 4/12/64	0044031504025	B 37	0044131504025	C 1
350 x 2,5 x 32	2/8,5/45 + 2/12/64 + 2/12,5/75	0044035003225	B 53	0044135003225	C 24
350 x 2,5 x 40	2/9/55 + 4/12/64	0044037004030	B 53	0044135003225	C 24

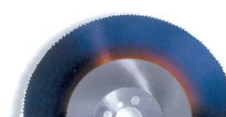

DIMENSIONES	TALADROS	TITANIO	PVP	PERFORMANCE 2000	PVP
250 x 2,5 x 32	2/8,5/45 + 2/11/63	0044225003225	B 36	0044325003225	B 48
250 x 2,5 x 40	2/8,5/45 + 2/11/63	0044225004025	B 36	0044325004025	B 48
275 x 2,5 x 32	2/8,5/45 + 2/11/63	0044227503225	B 44	0044327503225	C 6
275 x 2,5 x 40	2/8,5/45+2/12/64+4/9/50	0044227504025	B 44	0044327504025	C 6
300 x 2,5 x 32	2/8,5/45+2/11/63	0044230003225	C 5	0044330003225	C 20
300 x 2,5 x 40	2/8,5/45+2/12/64	0044230004025	C 5	0044330004025	C 20
315 x 2,5 x 32	2/8,5/45 + 2 /12/64	0044231503225	C 8	0044331503225	C 27
315 x 2,5 x 40	2/8,5/45 + 2/12/64	0044231504025	C 8	0044331504025	C 27
350 x 2,5 x 32	2/8,5/45 + 2/12/64	0044235003225	C 32	0044335003225	C 52
350 x 2,5 x 40	2/8,5/45 + 2/12/64+ 2/12,5/75	0044235004025	C 32	0044335004025	C 52

STEAM/ANTIGRIP . Consiste en un tratamiento superficial mediante la deposición de una capa de óxido anti-desgaste. La micro estructura de esta capa tiene la propiedad de ser porosa, lo que junto con el uso de un refrigerante produce un mejor enfriamiento y lubricación. Como resultado de estas propiedades se reduce el riesgo de que el disco gripe por rozadura.

TITANIO. Con el recubrimiento de nitruro de titanio el disco adquiere un color dorado. Las principales ventajas con respecto al resto de sierras son las siguientes.

- Mayor velocidad de corte (50 – 100%)
- Mayor vida útil (100-300 %)
- Menor resistencia a la fricción, y menor desgaste.

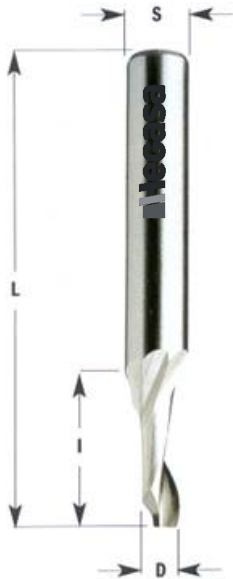

D	S	I	L	Z	REFERENCIA	PVP
3	8	12	60	1	U201,030,R	A 23
4	8	12	60	1	U201,040,R	A 23
4	8	40	100	1	U201,041,R	A 28
4	8	12	100	1	U201,042,R	A 28
5	8	14	70	1	U201,050,R	A 23
5	8	40	100	1	U201,051,R	A 28
5	8	14	100	1	U201,052,R	A 28
5	8	14	120	1	U201,053,R	A 28
5	8	25	70	1	U201,054,R	A 28
5	8	25	100	1	U201,055,R	A 30
5	8	40	120	1	U201,056,R	A 32
6	8	14	70	1	U201,060,R	A 23
6	8	40	100	1	U201,061,R	A 28
6	8	14	100	1	U201,062,R	A 28
6	8	25	70	1	U201,063,R	A 28
7	8	14	70	1	U201,070,R	A 28
8	8	14	80	1	U201,080,R	A 23
8	8	30	100	1	U201,081,R	A 28
8	8	14	100	1	U201,082,R	A 28
8	8	14	120	1	U201,083,R	A 28
8	8	25	80	1	U201,084,R	A 30
8	8	25	120	1	U201,085,R	A 32
9	8	14	80	1	U201,090,R	A 28
10	8	14	80	1	U201,100,R	A 28
10	8	14	100	1	U201,101,R	A 30
10	8	14	120	1	U201,102,R	A 32
12	8	14	80	1	U201,120,R	A 32

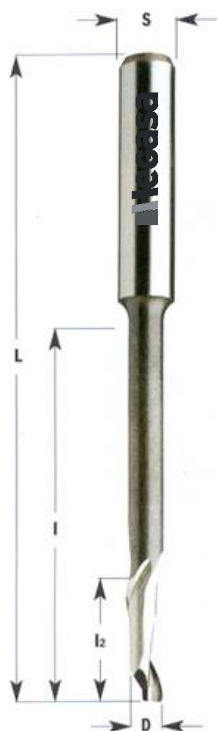

D	S	I	L	Z	REFERENCIA	PVP
4	8	16/55	90	1	U202,040,R	A 28
5	8	14/35	80	1	U202,050,R	A 23
5	8	14/35	120	1	U202,051,R	A 28
5	8	16/55	90	1	U202,052,R	A 28
5	8	18/35	100	1	U202,053,R	A 30
5	8	20/45	100	1	U202,054,R	A 31
6	8	14/55	85	1	U202,060,R	A 28
6	8	14/35	80	1	U202,061,R	A 28
6	8	14/45	90	1	U202,062,R	A 28
8	8	14/60	80	1	U202,080,R	A 28
8	8	14/90	120	1	U202,081,R	A 30
8	8	14/70	100	1	U202,082,R	A 28
8	8	30/70	100	1	U202,083,R	A 31
10	10	14/60	80	1	U202,100,R	A 33
10	10	14/70	100	1	U202,101,R	A 33
10	10	14/95	120	1	U202,102,R	A 34
10	10	30/70	100	1	U202,103,R	A 34

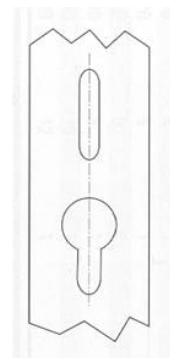

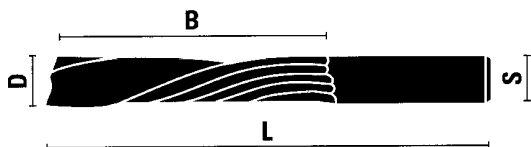

S = D	B	L	Z	REFERENCIA GIRO DERECHA	PVP
4	35	70	1	U101,040,R	A 47
5	35	70	1	U101,050,R	A 52
6	35	80	1	U101,060,R	B 2
8	35	80	1	U101,080,R	B 7
10	35	80	1	U101,100,R	B 13
12	35	80	1	U101,120,R	B 29

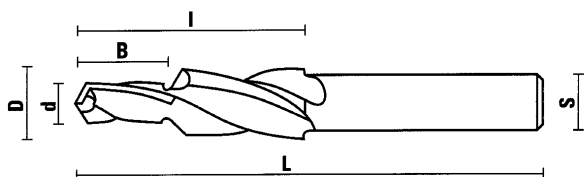

d/D	B/l	L	S	Z	REFERENCIA GIRO DERECHA	PVP
5,5/11,5	12/35	100	10	2	U290,055.R	B 4
6/11,5	12/35	100	10	2	U290,060.R	B 4
6/12	15/35	80	10	2	U290,061.R	B 4
6/14	15/35	80	10	2	U290,062.R	B 7
6,5/13,5	15/35	100	10	2	U290,065.R	B 7
7/13	12/35	100	10	2	U290,070.R	B 7
7/14	12,35	100	10	2	U290,071.R	B 7
7/15	12/35	100	10	2	U290,072.R	B 9
8/15	12/35	100	10	2	U290,080.R	B 9
12,7	41,3		102	2+2	190,508,11*	136
9,53	22,2		76	2+2	190,513,11*	90

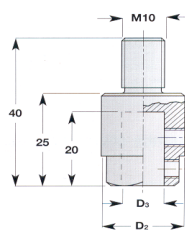

Para utilizar con portabrocas
Ref 302.080.11
TARIFA Pág. 190

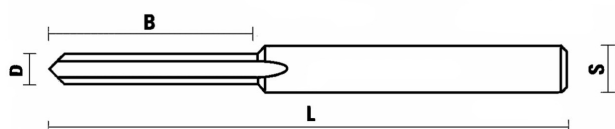

D	B	L	S	Z	REFERENCIA GIRO DERECHA	PVP
5	35	102	8	1	U240,050,R	A 35
5	45	102	8	1	U240,051,R	A 39
5	55	102	8	1	U240,052,R	A 45
6	30	102	8	1	U240,060,R	A 35

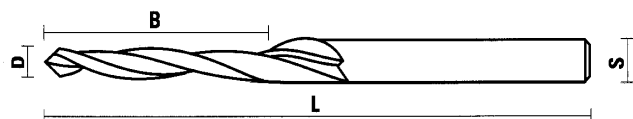

D	B	L	S	Z	REFERENCIA GIRO DERECHA	PVP
5	40	100	8	2	U 241,050,R	A 35

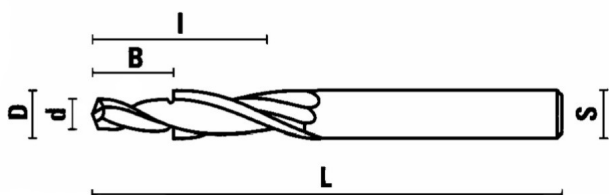

d/D	B/i	L	S	Z	REFERENCIA GIRO IZQUIERDAS	PVP
3/6	8/15	60	6	2	U230,030,R	A 35

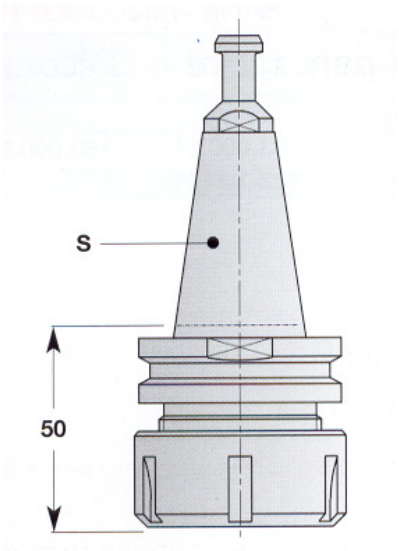

MANDRINO PORTA PINZAS DE PRECIÓN ISO 30

MARCA DE LA MAQUINA	REFERENCIA GIRO DERECHA	REFERENCIA GIRO IZQUIERDA	PVP
	183,200,01	183,200,02	B 41
	183,210,01	183,210,02	B 41
	183,210,01	183,210,02	B 41

TIRANTE	REFERENCIA	PVP
Ø 12 Ø 8 PARA MANDRINO 183,200	995,200,00	A 34
Ø 13 Ø 8 PARA MANDRINO 183,210	995,201,00	A 34
Ø 12,8 Ø 9 PARA MANDRINO 183,220	995,202,00	A 34

PINZA ER 32
TUERCA DE APRIETE PINZA 992.183.01– 992.183.02

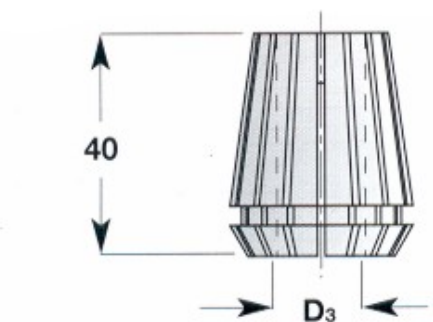

PINZA ELÁSTICA BICÓNICA ER- 32

Para mandrinos: 183.000 / 183.100 / 183.200
183.250 / 183.300 / 183.400

D ₃ = Ø MANGO HERRAMIENTAS	REFERENCIA	PVP
3	184,030,00	A 39
4	184,040,00	A 39
5	184,050,00	A 39
6	184,060,00	A 39
7	184,070,00	A 39
8	184,080,00	A 39
10	184,100,00	A 39
12	184,120,00	A 39
13	184,130,00	A 39
14	184,140,00	A 39
16	184,160,00	A 39
18	184,180,00	A 39
19	184,190,00	A 39
20	184,200,00	A 39

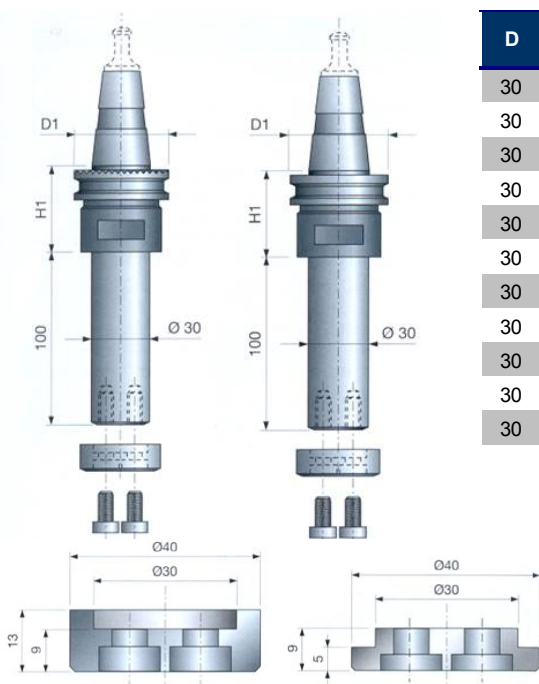

D	MANGO	H1	L	MAQUINA	REFERENCIA	PVP
30	ISO 30	35	70		T128,790,N	B 47
30	ISO 30	35	100		T128,800 N	B 47
30	ISO 30	35	70		T128,791,N	B 47
30	ISO 30	35	100		T128,801,N	B 47
30	ISO 30	35	70		T128,792,N	B 47
30	ISO 30	35	100		T128,802,N	B 47
30	ISO 30	35	100		T128,804,N	C 50
30	ISO 30	35	100		T128,805N	C 45
30	ISO 30	35	100		T128,850N	C 45
30	ISO 30	39	70		T128,690N	C 8
30	ISO 30	39	100		T128,700N	C 8

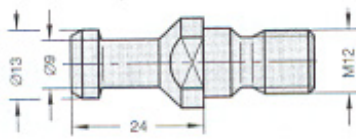

Nº 1
 IMA - MAKA - REICHENBACHER - WECKE
 BULLERI - COSMEC - LARI E LARI - ESSETEAN

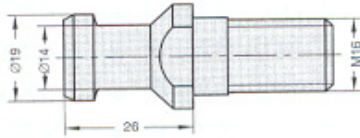

Nº 2
 IMA - MAKA - REICHENBACHER - STEGHERR

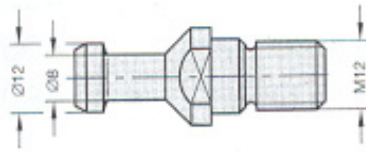

Nº 3
 BIESSE antes del 09/1992

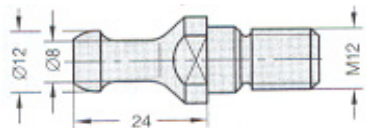

Nº 4
 BIESSE después del 10/1992 (motores HSD)
 EGURKO- ORTZA - MASTERWOOD - BULLERI

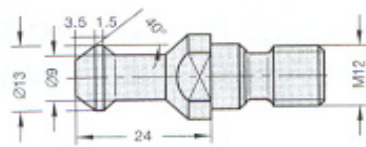

Nº 5
 ALBERTINI - VITAP - MASTERWOOD
 BELLOTTI (Motores Colombo)

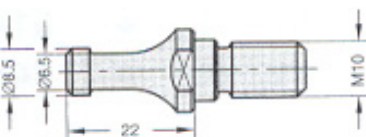

Nº 6
 MORBIDELLI - SCM

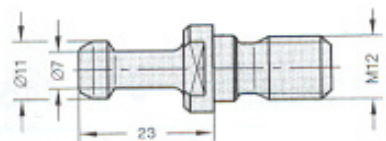

Nº 7
 SHODA

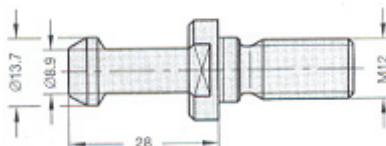

Nº 8
 HEIAN

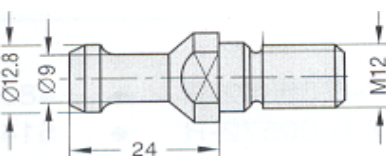

Nº 9
 CMS

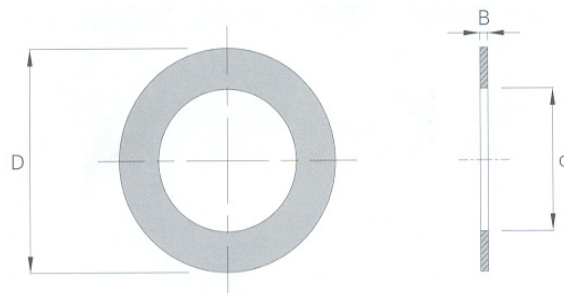

d	D	H	REFERENCIA	PVP
30	50	2	0171303005000200	A 8
30	50	3	0171303005000300	A 8
30	50	4	0171303005000400	A 9
30	50	5	0171303005000500	A 9
30	50	6	0171303005000600	A 10
30	50	7	0171303005000700	A 10
30	50	8	0171303005000800	A 11
30	50	9	0171303005000900	A 12
30	50	10	0171303005001000	A 13
30	50	11	0171303005001100	A 13
30	50	12	0171303005001200	A 14
30	50	14	0171303005001400	A 14
30	50	15	0171303005001500	A 14
30	50	16	0171303005001600	A 16
30	50	18	0171303005001800	A 16
30	50	20	0171303005002000	A 17
30	50	25	0171303005002500	A 20
30	50	30	0171303005003000	A 21
30	50	40	0171303005004000	A 22
30	50	50	0171303005005000	A 24

d	D	H	REFERENCIA	PVP
32	50	2	0171303205000200	A 13
32	50	3	0171303205000300	A 13
32	50	4	0171303205000400	A 15
32	50	5	0171303205000500	A 15
32	50	6	0171303205000600	A 16
32	50	7	0171303205000700	A 16
32	50	8	0171303205000800	A 17
32	50	9	0171303205000900	A 17
32	50	10	0171303205001000	A 18
32	50	11	0171303205001100	A 18
32	50	12	0171303205001200	A 19
32	50	14	0171303205001400	A 20
32	50	15	0171303205001500	A 20
32	50	16	0171303205001600	A 21
32	50	18	0171303205001800	A 21
32	50	20	0171303205002000	A 22
32	50	25	0171303205002500	A 23
32	50	30	0171303205003000	A 24
32	50	40	0171303205004000	A 27
32	50	50	0171303205005000	A 30

D	d	H	REFERENCIA	PVP
40	60	2	0171304006000200	A 8
40	60	3	0171304006000300	A 9
40	60	4	0171304006000400	A 9
40	60	5	0171304006000500	A 10
40	60	6	0171304006000600	A 11
40	60	7	0171304006000700	A 11
40	60	8	0171304006000800	A 12
40	60	9	0171304006000900	A 12
40	60	10	0171304006001000	A 13
40	60	11	0171304006001100	A 13
40	60	12	0171304006001200	A 14
40	60	14	0171304006001400	A 14
40	60	15	0171304006001500	A 15
40	60	16	0171304006001600	A 17
40	60	18	0171304006001800	A 17
40	60	20	0171304006002000	A 19
40	60	25	0171304006002500	A 20
40	60	30	0171304006003000	A 22
40	60	40	0171304006004000	A 24
40	60	50	0171304006005000	A 27

d	D	H	REFERENCIA	PVP
50	70	2	0171305007000200	A 8
50	70	3	0171305007000300	A 9
50	70	4	0171305007000400	A 10
50	70	5	0171305007000500	A 10
50	70	6	0171305007000600	A 12
50	70	7	0171305007000700	A 12
50	70	8	0171305007000800	A 12
50	70	9	0171305007000900	A 13
50	70	10	0171305007001000	A 14
50	70	11	0171305007001100	A 14
50	70	12	0171305007001200	A 15
50	70	14	0171305007001400	A 16
50	70	15	0171305007001500	A 16
50	70	16	0171305007001600	A 18
50	70	18	0171305007001800	A 19
50	70	20	0171305007002000	A 19
50	70	25	0171305007002500	A 21
50	70	30	0171305007003000	A 23
50	70	40	0171305007004000	A 25
50	70	50	0171305007005000	A 28



Juego de anillos separadores para el relleno de ejes de máquinas. Compuesto por 21 anillos de las siguientes medidas:

2-3-4-5-6-7-8-9-10-11-12-14-15-16-18-20-25 - 30-40 y 50 mm

d	D	REFERENCIA	PVP
30	50	0171303005010000	C 25
32	50	0171303205010000	C 42
40	60	0171304006010000	C 22
50	70	0171305007010000	C 27

Juego de anillos decimales para regular la separación de herramientas. Cada juego lleva dos piezas de cada medida de las indicadas en la columna COMPOSICIÓN de la tabla que se muestra a continuación.

d	D	COMPOSICION	REFERENCIA	PVP
20	50	0,1-0,2-0,3-0,5-1,0	0171302005010000	A 15
22	50	0,1-0,2-0,3-0,5-1,0	0171302205010000	A 15
27	50	0,1-0,2-0,3-0,5-1,0	0171302705010000	A 21
30	50	0,1-0,2-0,3-0,5-1,0-2,0-3,0	0171303005010000	A 17
32	50	0,1-0,2-0,3-0,5-1,0-2,0-3,0	0171303205010000	A 23
35	55	0,1-0,2-0,3-0,5-1,0-2,0-3,0	0171303505510000	A 17
40	60	0,1-0,2-0,3-0,5-1,0-2,0-3,0	0171304006010000	A 21
50	70	0,1-0,2-0,3-0,5-1,0-2,0-3,0	0171305007010000	A 21
60	80	0,1-0,2-0,3-0,5-1,0-2,0-3,0	0171306008010000	A 26
65	85	0,1-0,2-0,3-0,5	0171306508510000	A 26