

# LA CALIDAD A SU SERVICIO

Diseño, fabricación y mantenimiento de herramientas de corte.

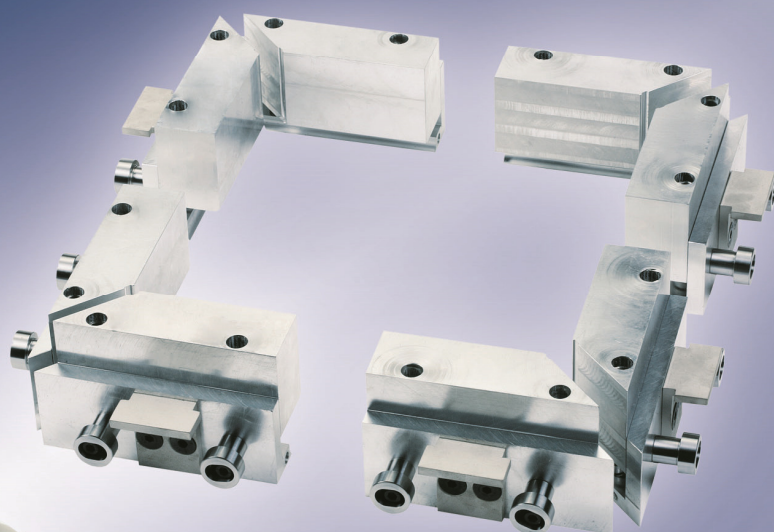

## CATÁLOGO PVC

**WINTTECH**®

**Hegasa**

HERRAMIENTAS DE GALICIA S.A.

# ÍNDICE

## PVC

<b>WINTECH SERIE W 632</b>	<b>PAG. 1 - 9</b>
<b>WINTECH SERIE W 750 / 75</b>	<b>PAG. 10 - 17</b>
<b>WINTECH SERIE W 242 CORREDERA</b>	<b>PAG. 18 - 19</b>
<b>WINTECH SERIE W 232 CORREDERA</b>	<b>PAG. 20 - 21</b>
<b>WINTECH SEIE W 222 CORREDERA</b>	<b>PAG. 22 - 23</b>
<b>WINTECH PLANTILLA JUNQUILLOS</b>	<b>PAG. 24</b>
<b>PIEZAS ACOPLA A MAQUINAS SOLDAR</b>	<b>PAG. 25 - 28</b>
<b>HUSILLOS PORTA HERRAMIENTAS</b>	<b>PAG. 29 - 31</b>
<b>DISCOS DE CORTE</b>	<b>PAG. 32 - 35</b>
<b>BROCAS Y MANDRINOS PORTA PINZAS</b>	<b>PAG. 36- 39</b>
<b>ANILLOS SEPARADORES - ANILLOS DECIMALES</b>	<b>PAG. 40- 41</b>

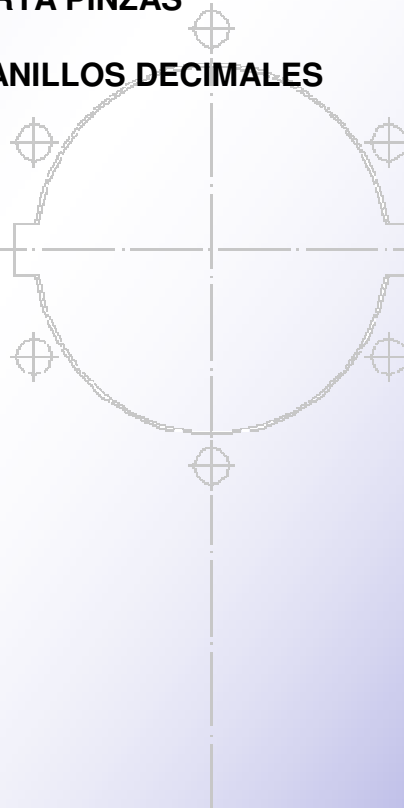

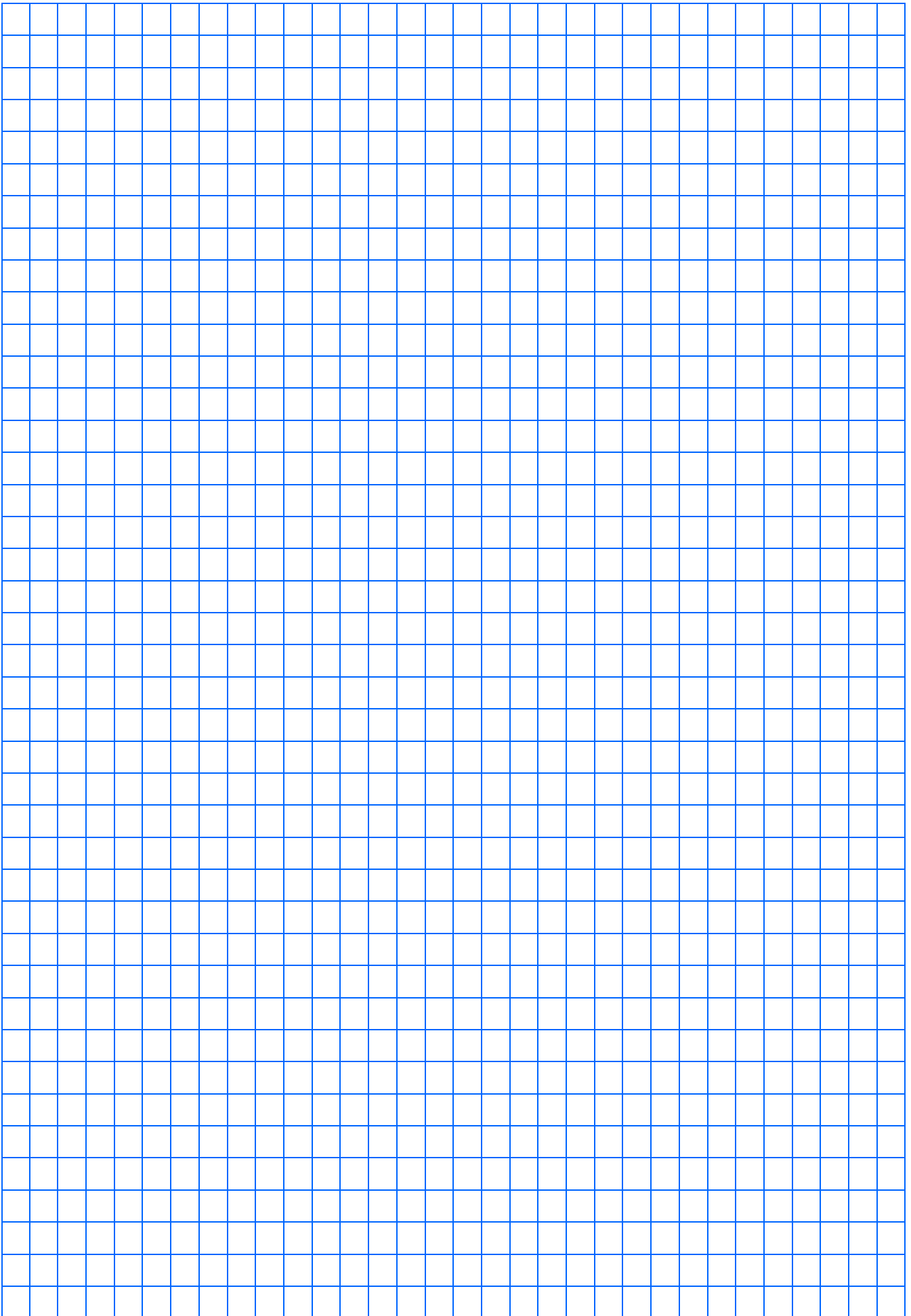

**WINTECH®**

**CONJUNTO FRESAS LIMPIEZA MARCOS  
SERIE . S 632**

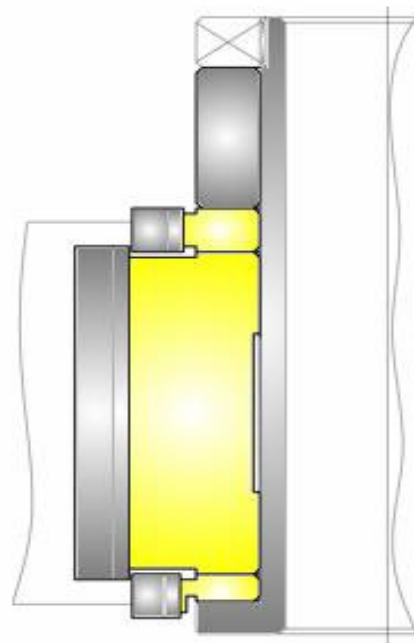

**CONJUNTO FRESAS LIMPIEZA  
MARCO RENOVACION  
SERIE . S 632**

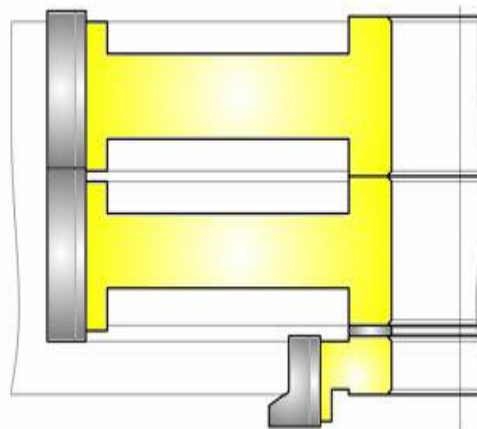

EN EL PRECIO NO ESTAN INCLUIDOS LOS HUSILLOS PORTA HERRAMIENTAS

**WINTECH®**

PVC

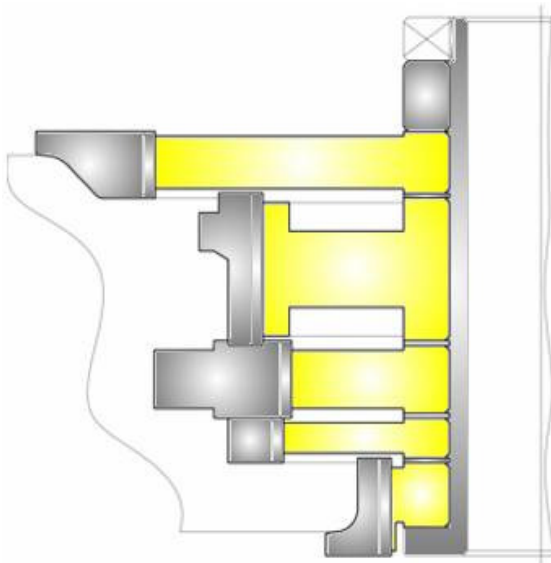

**CONJUNTO FRESAS LIMPIEZA HOJAS  
RECTAS + AUSTRIACA  
SERIE .S 632**

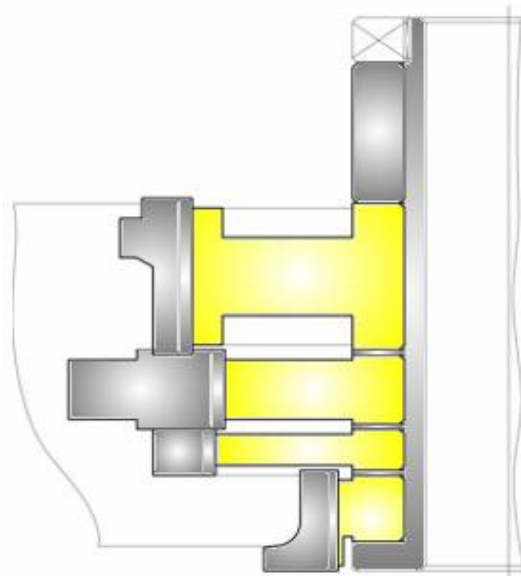

**CONJUNTO FRESAS LIMPIEZA HOJAS  
RECTA  
SERIE . S 632**

EN EL PRECIO NO ESTAN INCLUIDOS LOS HUSILLOS PORTA HERRAMIENTAS

**WINTECH®**

PVC

CONJUNTO FRESAS RETESTAR  
TRAVESAÑO SERIE . S 632

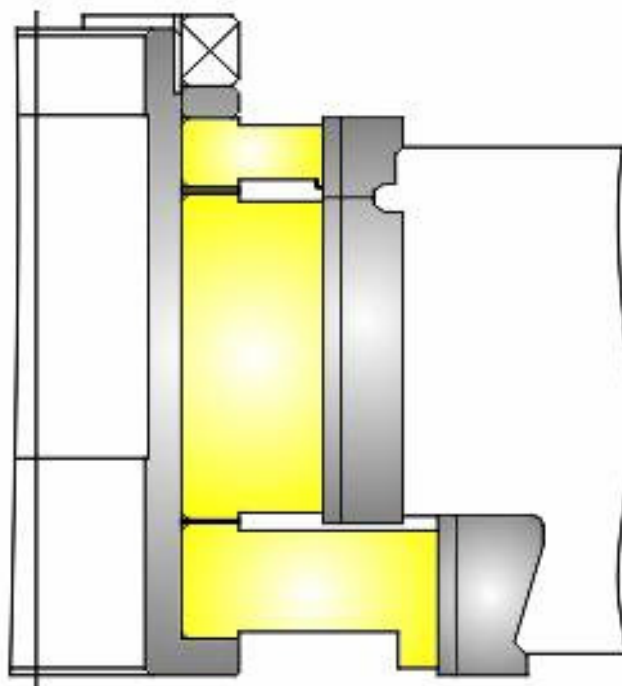

EN EL PRECIO NO ESTAN INCLUIDOS LOS HUSILLOS PORTA HERRAMIENTAS

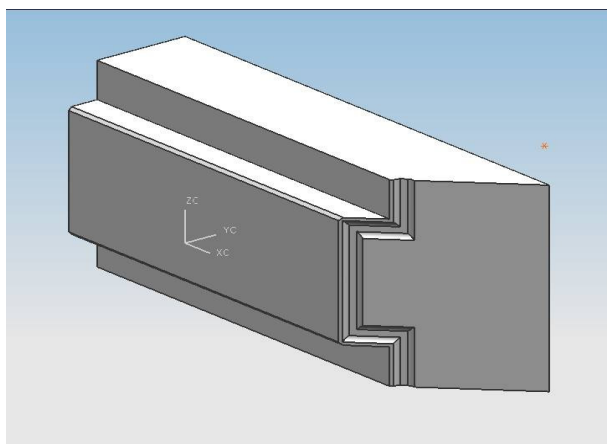

**CONTRAFORMA SOLDAR MARCO  
SERIE . S 632**

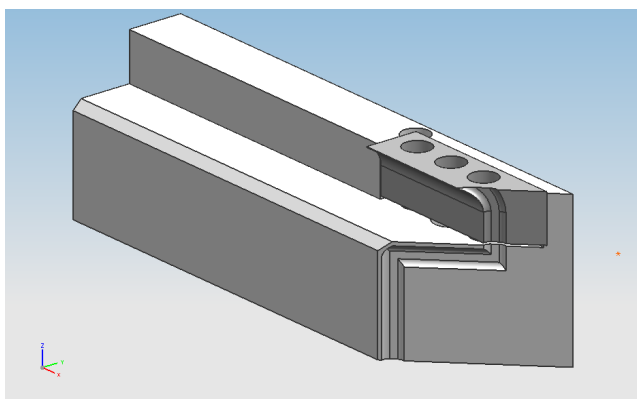

**CONTRAFORMA SOLDAR MARCO RENOVACION  
SERIE . S 632**

EN EL PRECIO NO ESTAN INCLUIDAS LAS PIEZAS DE SUJECION DE LAS MAQUINAS

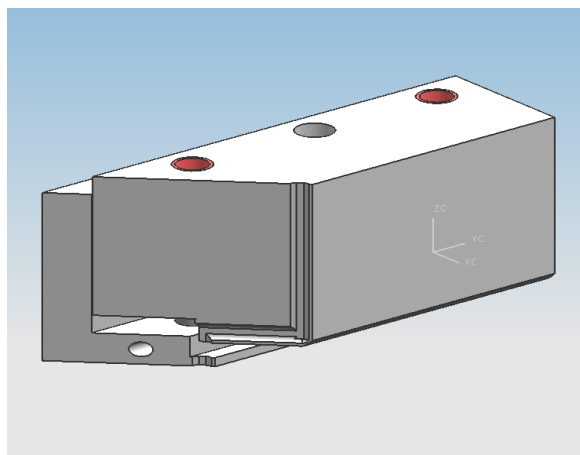
**WINTECH®****CONTRAFORMA SOLDAR MARCO RENOVACION  
SERIE . S 632****CONTRA EN DOS PIEZAS CON MUELLES****EN EL PRECIO NO ESTAN INCLUIDAS LAS PIEZAS DE SUJECION DE LAS MAQUINAS**



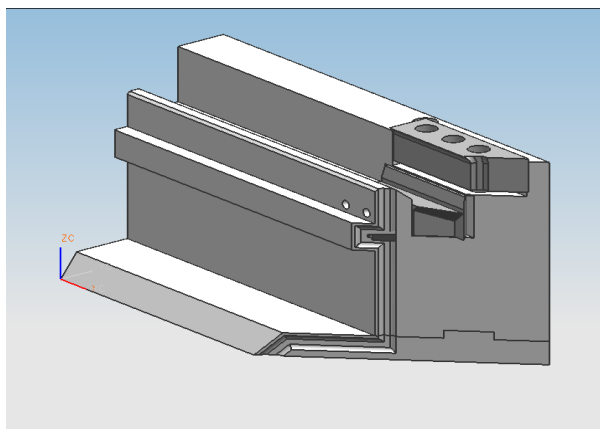

**CONTRAFORMA SOLDAR HOJAS  
SERIE S 632  
CONTRA CON PLETINA PARA HOJA AUSTRIACA**

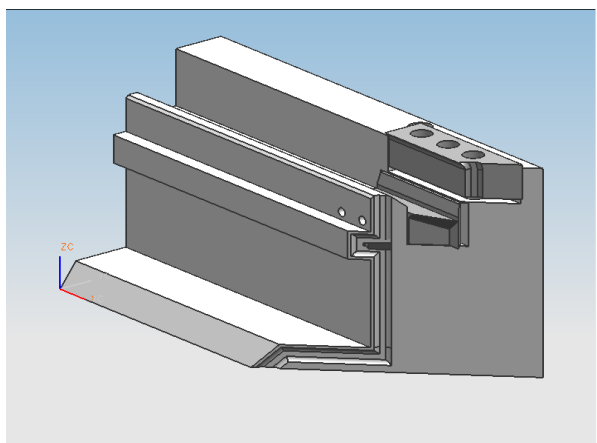

**CONTRAFORMA SOLDAR HOJA AUSTRIACA  
SERIE . S 632**

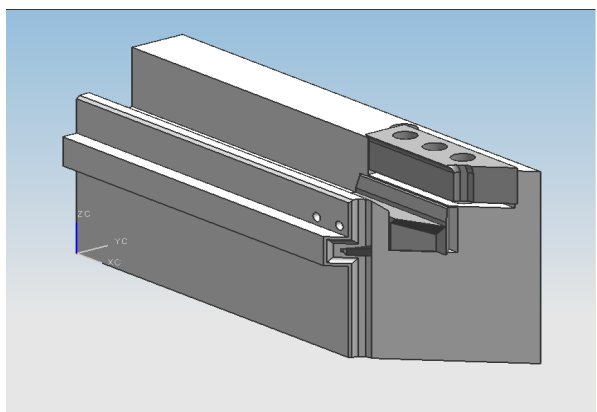

**CONTRAFORMA SOLDAR HOJA RECTA  
SERIE. S 632**

EN EL PRECIO NO ESTAN INCLUIDAS LAS PIEZAS DE SUJECION DE LAS MAQUINAS

**WINTECH®**

**CONTRAFORMA SOLDAR HOJAS  
SERIE . S632  
HOJA RECTA + PLETINA PARA AUSTRIACA**

**CONTRA EN DOS PIEZAS CON MUELLES**

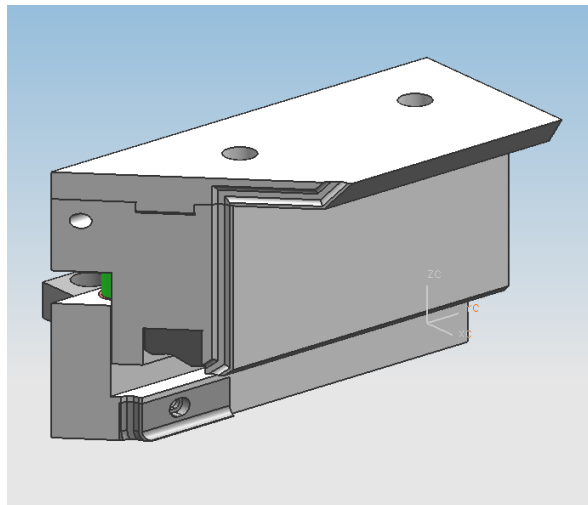

**CONTRAFORMA SOLDAR HOJAS AUSTRIACA  
SERIE S 632**

**CONTRA EN DOS PIEZAS CON MUELLES**

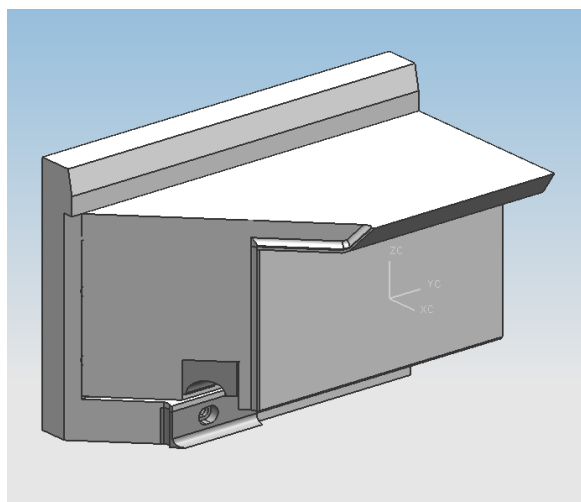

**CONTRAFORMA SOLDAR HOJA RECTA  
SERIE S632**

**CONTRA EN DOS PIEZAS CON MUELLES**

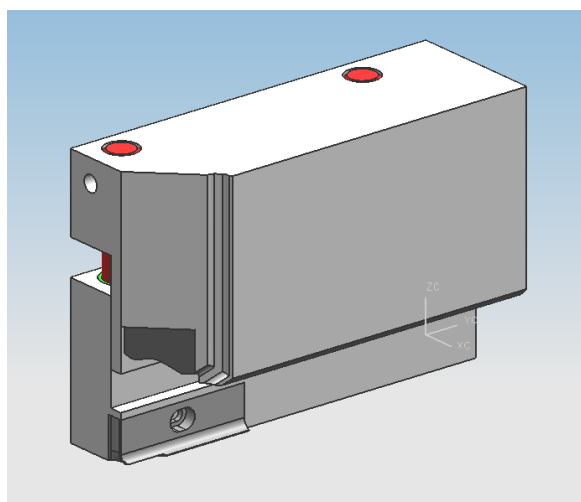

EN EL PRECIO NO ESTAN INCLUIDAS LAS PIEZAS DE SUJECION DE LAS MAQUINAS

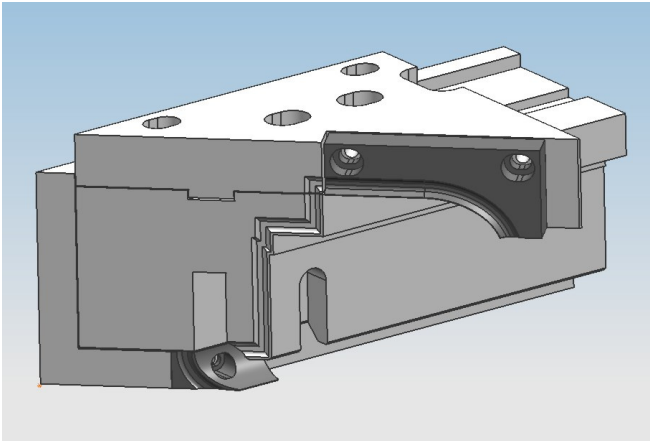

**CONTRAFORMA SOLDAR ENVOLVENTE  
PERFIL HOJA AUSTRIACA**

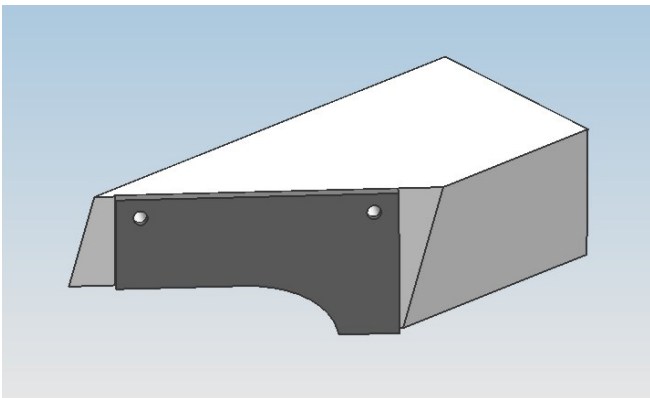

**CUCHILLA REPASADORA DE CORDON INTERIOR  
PERFIL HOJA AUSTRIACA**

EN EL PRECIO NO ESTAN INCLUIDAS LAS PIEZAS DE SUJECION DE LAS MAQUINAS

**WINTECH®**

PVC

**CONJUNTO FRESAS LIMPIEZA MARCOS  
SERIE . S 750—752**

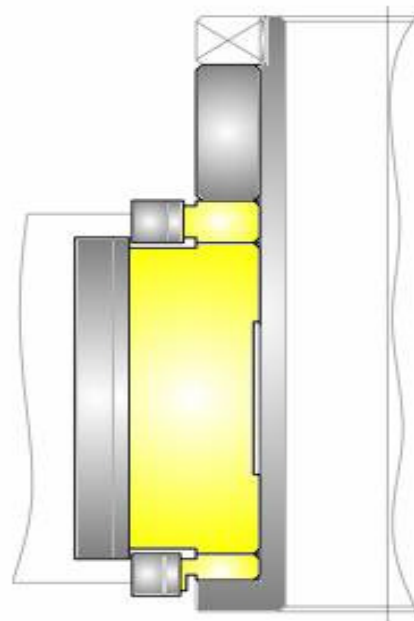

**CONJUNTO FRESAS LIMPIEZA  
MARCO RENOVACION  
SERIE . S 750—752**

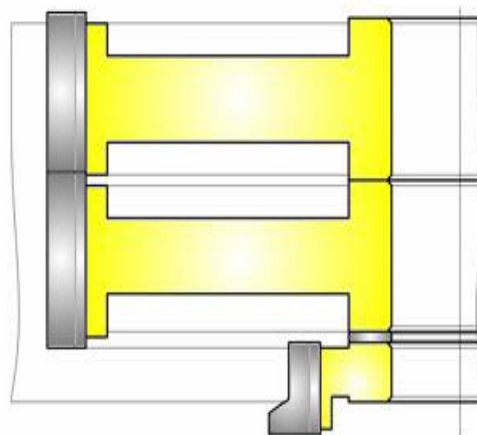

EN EL PRECIO NO ESTAN INCLUIDOS LOS HUSILLOS PORTA HERRAMIENTAS

**WINTECH®**

PVC

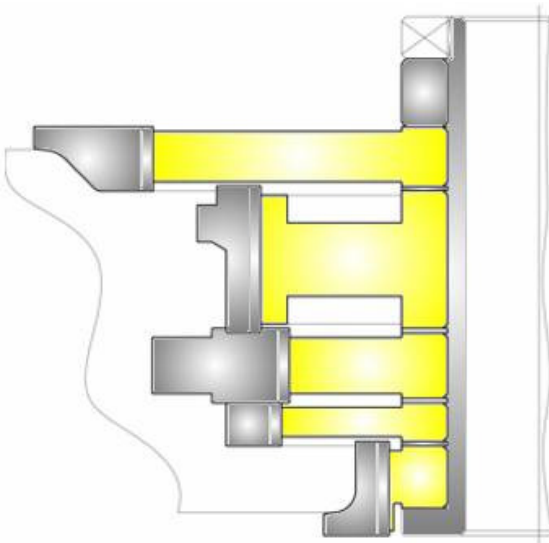

**CONJUNTO FRESAS LIMPIEZA HOJAS  
RECTAS + AUSTRIACA  
SERIE .S 750—752**

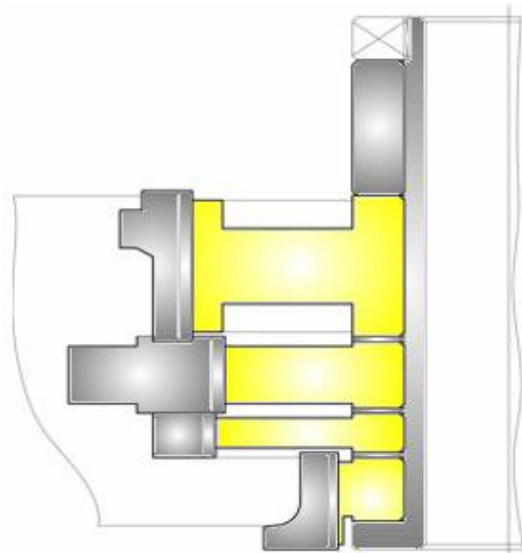

**CONJUNTO FRESAS LIMPIEZA HOJAS  
RECTA  
SERIE . S 750—752**

EN EL PRECIO NO ESTAN INCLUIDOS LOS HUSILLOS PORTA HERRAMIENTAS

**WINTECH®**

PVC

CONJUNTO FRESAS RETESTAR  
TRAVESAÑO SERIE . S 750 - 752

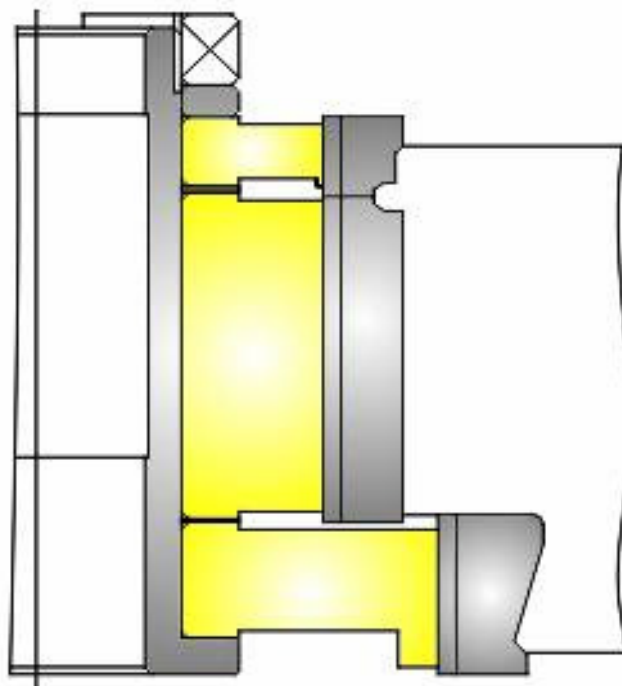

EN EL PRECIO NO ESTAN INCLUIDOS LOS HUSILLOS PORTA HERRAMIENTAS

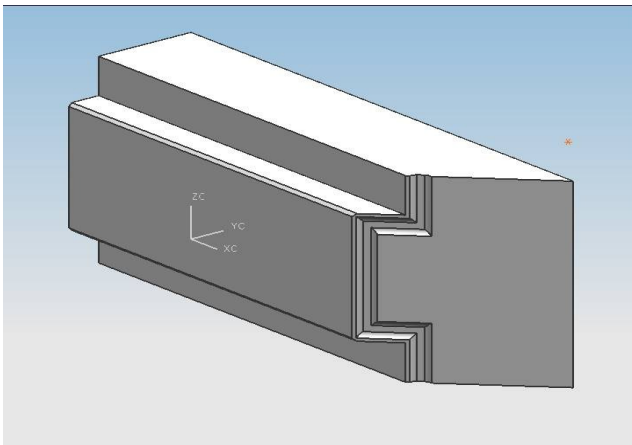

**CONTRAFORMA SOLDAR MARCO  
SERIE . S 750—752**

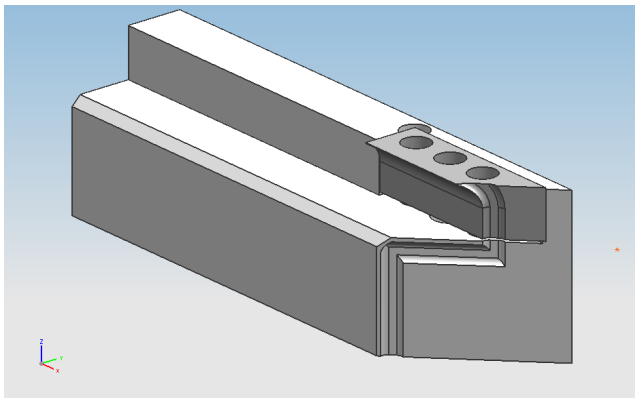

**CONTRAFORMA SOLDAR MARCO RENOVACION  
SERIE . S 750—752**

EN EL PRECIO NO ESTAN INCLUIDAS LAS PIEZAS DE SUJECION DE LAS MAQUINAS

**WINTECH®**

PVC

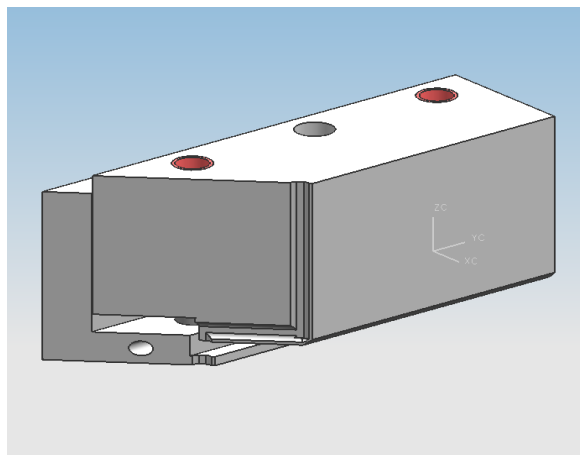
**CONTRAFORMA SOLDAR MARCO RENOVACION  
SERIE . S 632****CONTRA EN DOS PIEZAS CON MUELLES****EN EL PRECIO NO ESTAN INCLUIDAS LAS PIEZAS DE SUJECION DE LAS MAQUINAS**



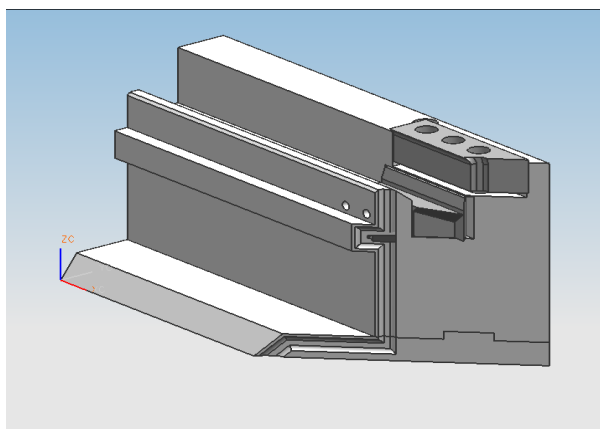

CONTRAFORMA SOLDAR HOJAS  
SERIE S 750—752  
CONTRA CON PLETINA PARA HOJA AUSTRIACA

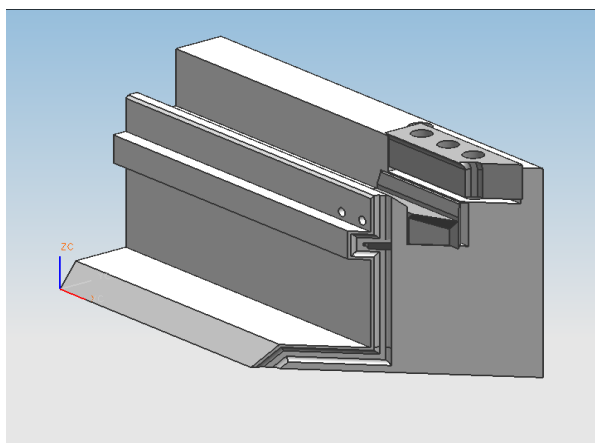

CONTRAFORMA SOLDAR HOJA AUSTRIACA  
SERIE . S 750—752

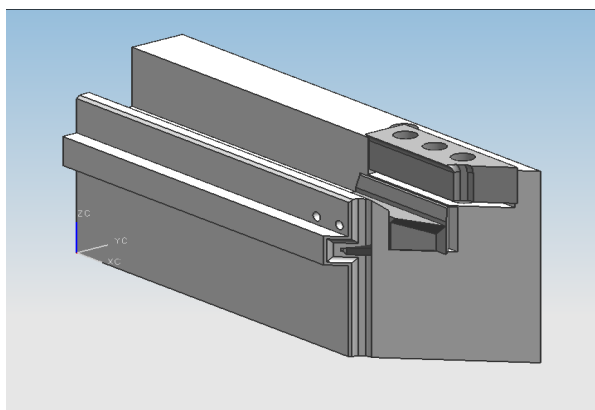

CONTRAFORMA SOLDAR HOJA RECTA  
SERIE. S 750—752

EN EL PRECIO NO ESTAN INCLUIDAS LAS PIEZAS DE SUJECION DE LAS MAQUINAS

**WINTeCH®**

**CONTRAFORMA SOLDAR HOJAS  
SERIE . S 750 - 752  
HOJA RECTA + PLETINA PARA AUSTRIACA**

**CONTRA EN DOS PIEZAS CON MUELLES**

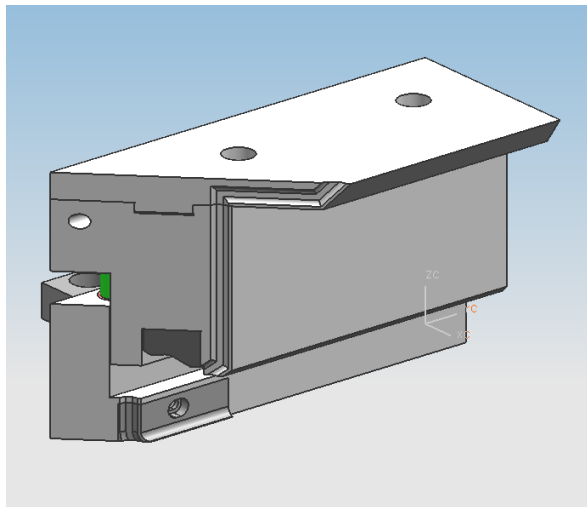

**CONTRAFORMA SOLDAR HOJAS AUSTRIACA  
SERIE S 750 - 752**

**CONTRA EN DOS PIEZAS CON MUELLES**

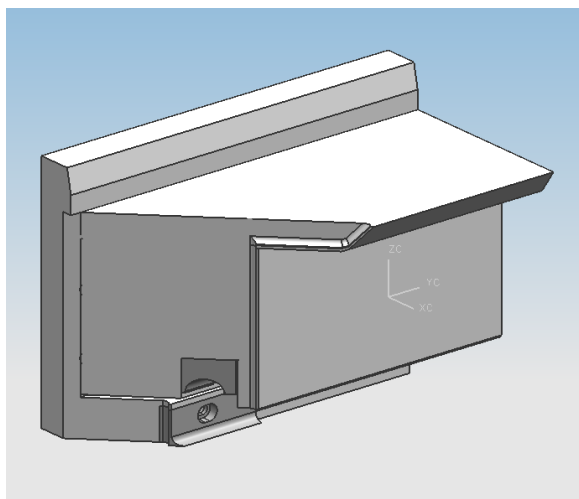

**CONTRAFORMA SOLDAR HOJA RECTA  
SERIE S 750 - 752**

**CONTRA EN DOS PIEZAS CON MUELLES**

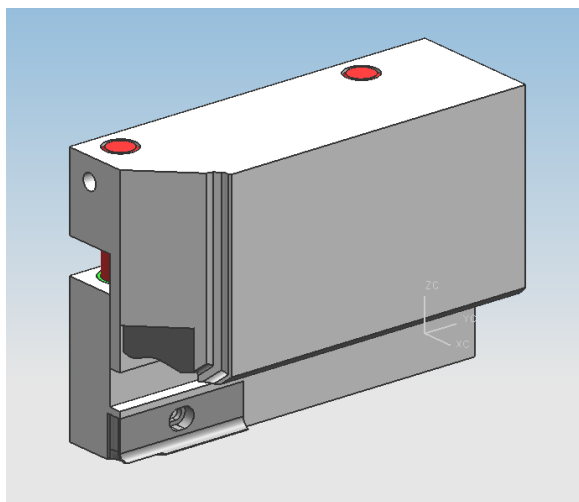

EN EL PRECIO NO ESTAN INCLUIDAS LAS PIEZAS DE SUJECION DE LAS MAQUINAS

**WINTTECH®**

PVC

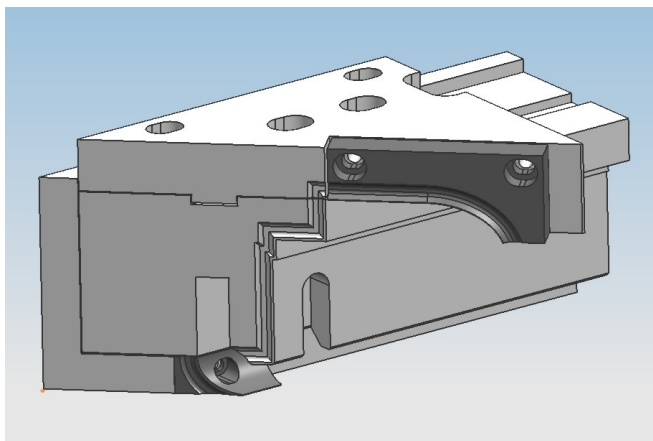

**CONTRAFORMA SOLDAR ENVOLVENTE  
PERFIL SERIE 750—752 HOJA AUSTRIACA**

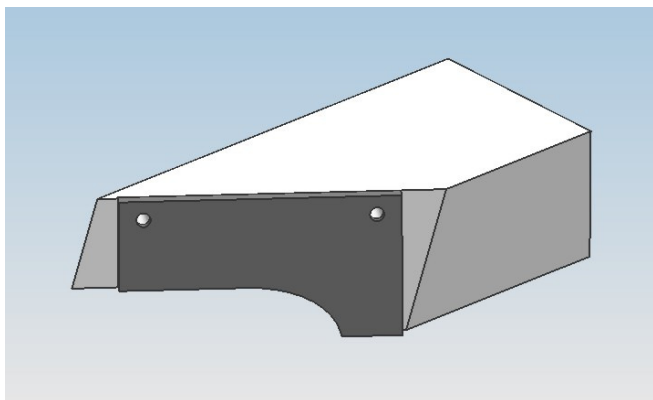

**CUCHILLA REPASADORA DE CORDON INTERIOR  
PERFIL SERIE 750—752 HOJA AUSTRIACA**

**EN EL PRECIO NO ESTAN INCLUIDOS LOS HUSILLOS PORTA HERRAMIENTAS**

**WINTECH®**

**CONJUNTO LIMPIEZA HOJA  
CORREDERA W 242 PERFIL 21306.15000**

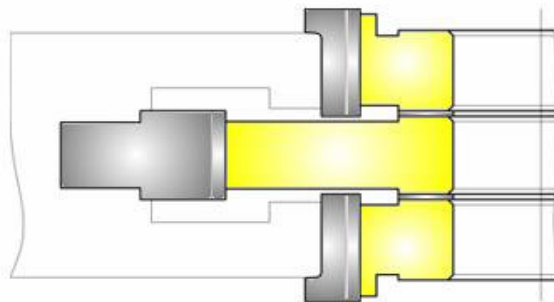

**CONJUNTO FRESAS LIMPIEZA  
MARCO CORREDERA W 242  
PERFIL 21408.01000**

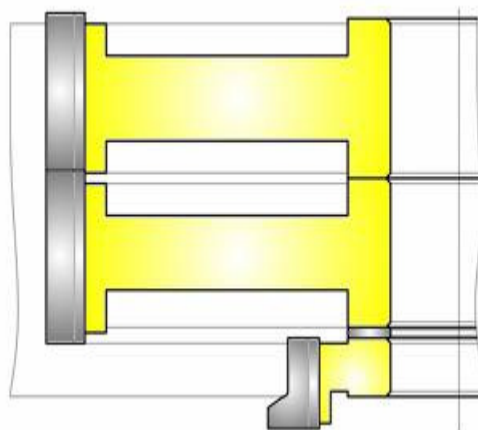

**FRESA RETESTAR TRAVESAÑO  
CORREDERA W 242 PERFIL 21305.03000**

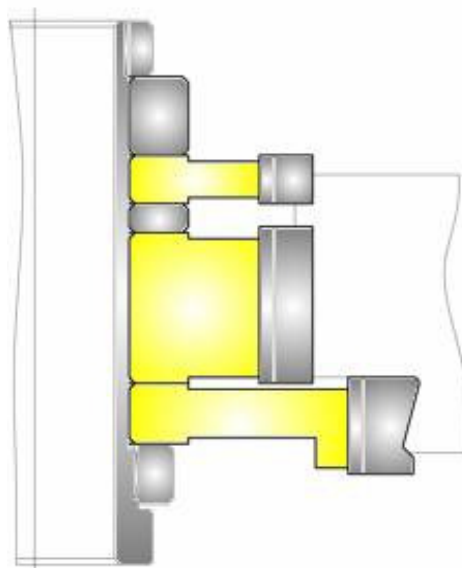

EN EL PRECIO NO ESTAN INCLUIDOS LOS HUSILLOS PORTA HERRAMIENTAS

WINTeCH®

PVC

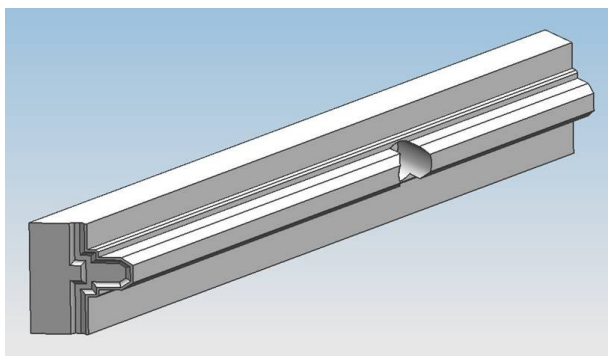

CONTRAFORMA SOLDAR HOJA  
CORREDERA W 242 PERFIL 21306 .15000

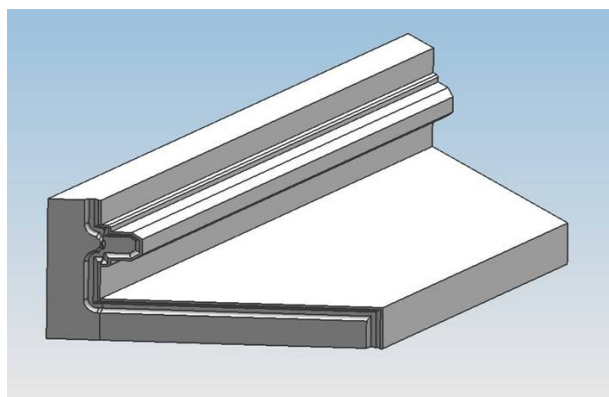

CONTRAFORMA SOLDAR HOJA  
CORREDERA W 242 PERFIL 21306.15000  
CON SUPLEMENTO DE ALTURA

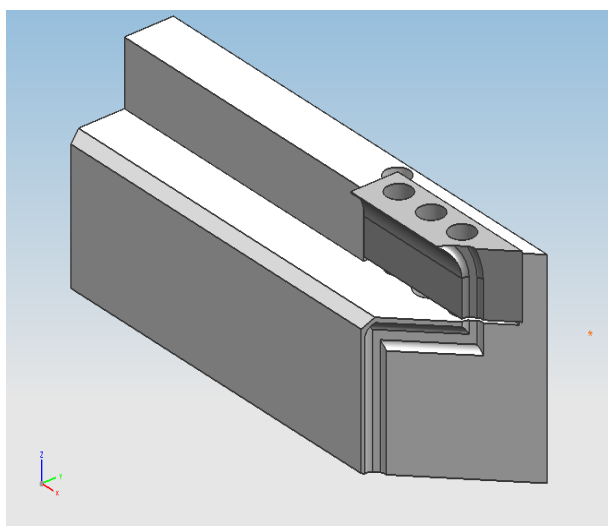

CONTRAFORMA SOLDAR  
MARCO CORREDERA W 242  
PERFIL 21408.01000

EN EL PRECIO NO ESTAN INCLUIDAS LAS PIEZAS DE SUJECION DE LAS MAQUINAS

**WINTECH®**

**CONJUNTO LIMPIEZA HOJA  
CORREDERA W 232 PERFIL 21306.15000**

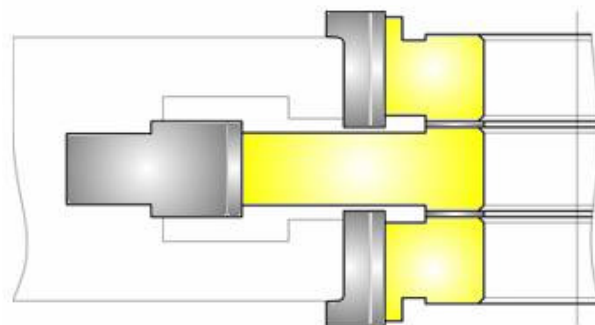

**CONJUNTO FRESAS LIMPIEZA  
MARCO CORREDERA W 232  
PERFILES . 21406.12000 / 21306.01000**

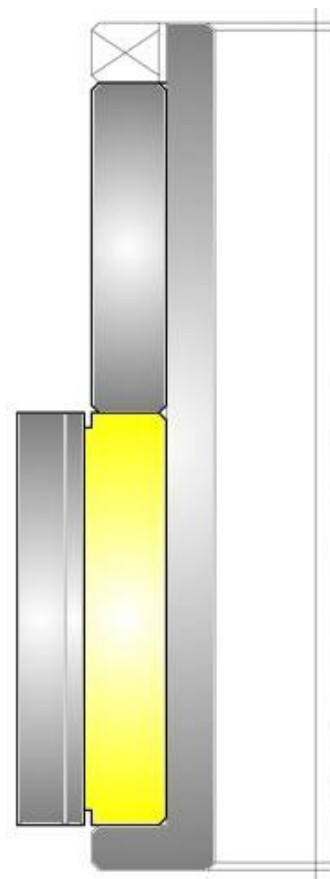

EN EL PRECIO NO ESTAN INCLUIDOS LOS HUSILLOS PORTA HERRAMIENTAS

WINTeCH®

PVC

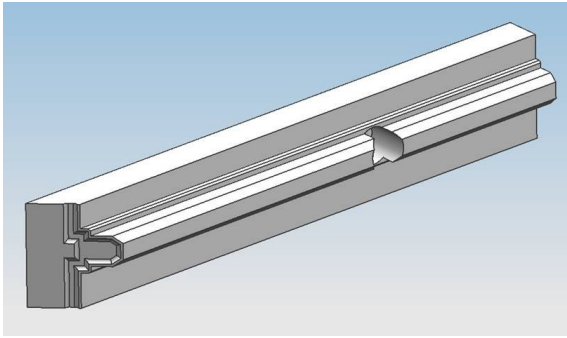

CONTRAFORMA SOLDAR HOJA  
CORREDERA W 232 PERFIL 21306 .15000

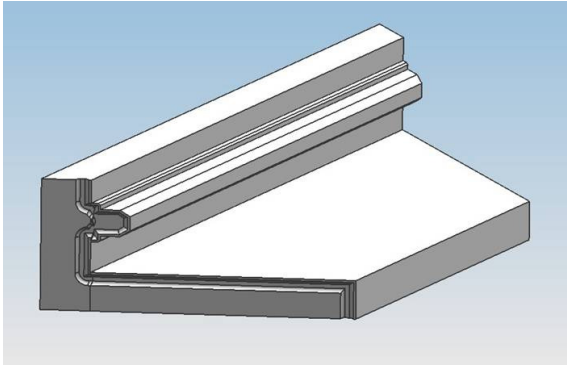

CONTRAFORMA SOLDAR HOJA  
CORREDERA W 232 PERFIL 21306.15000  
CON SUPLEMENTO DE ALTURA

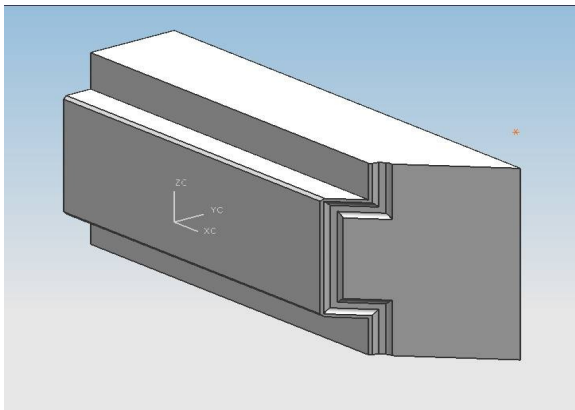

CONTRAFORMA SOLDAR HOJA  
CORREDERA W 232 PERFIL 21306 -01000

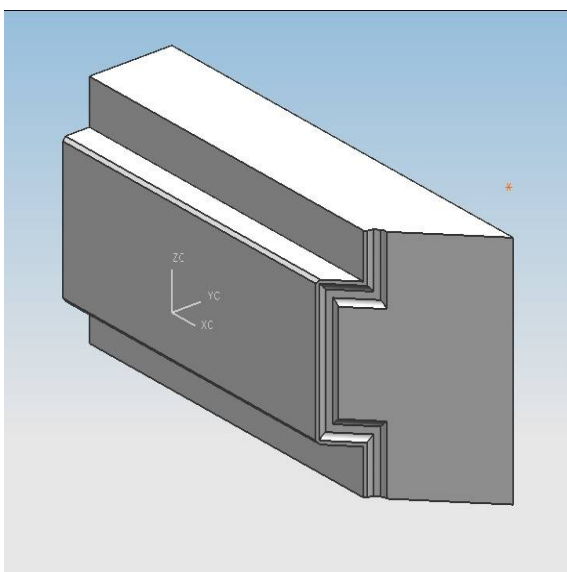

CONTRAFORMA SOLDAR HOJA  
CORREDERA W 232 PERFIL 21406-12000

EN EL PRECIO NO ESTAN INCLUIDAS LAS PIEZAS DE SUJECION DE LAS MAQUINAS

**WINTECH®**

**CONJUNTO LIMPIEZA HOJA  
CORREDERA W 222**

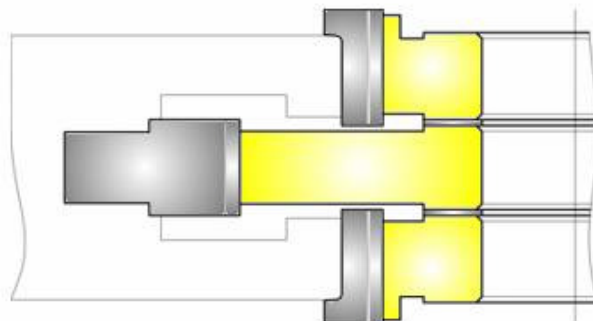

**CONJUNTO FRESAS LIMPIEZA  
MARCO CORREDERA W 222**

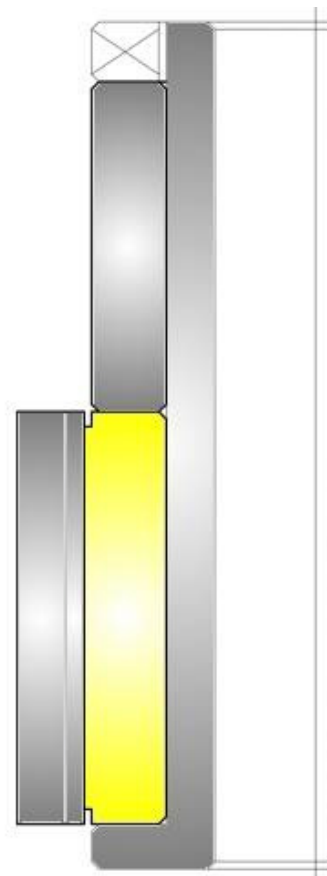

EN EL PRECIO NO ESTAN INCLUIDOS LOS HUSILLOS PORTA HERRAMIENTAS



WINTECH®

PVC

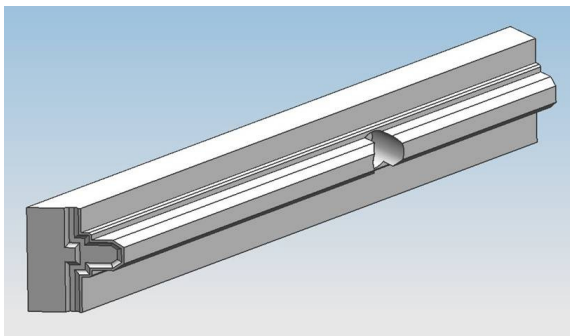

CONTRAFORMA SOLDAR HOJA  
CORREDERA W 222

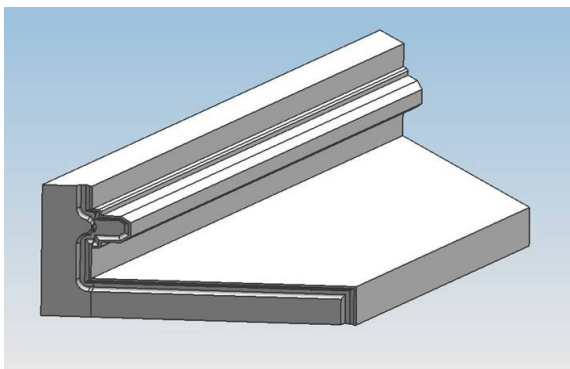

CONTRAFORMA SOLDAR HOJA  
CORREDERA W 222  
CON SUPLEMENTO DE ALTURA

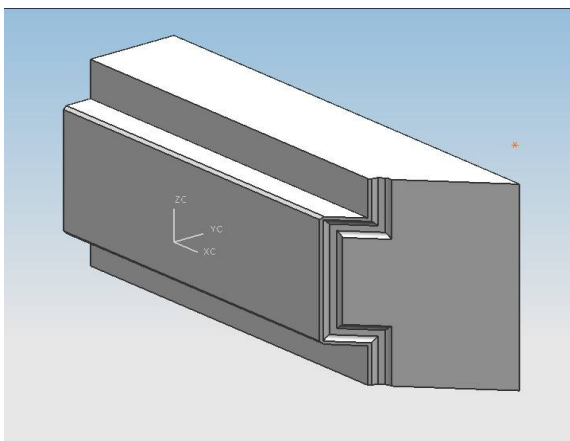

CONTRAFORMA SOLDAR HOJA  
CORREDERA W 222

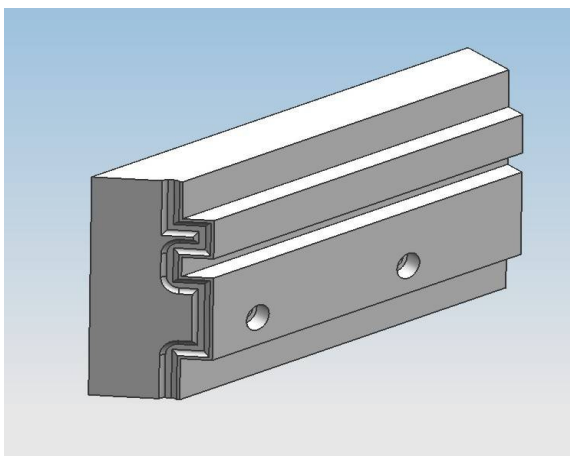

CONTRAFORMA SOLDAR MARCO  
CORREDERA W 222

EN EL PRECIO NO ESTAN INCLUIDAS LAS PIEZAS DE SUJECION DE LAS MAQUINAS

**WINTECH®**

PVC

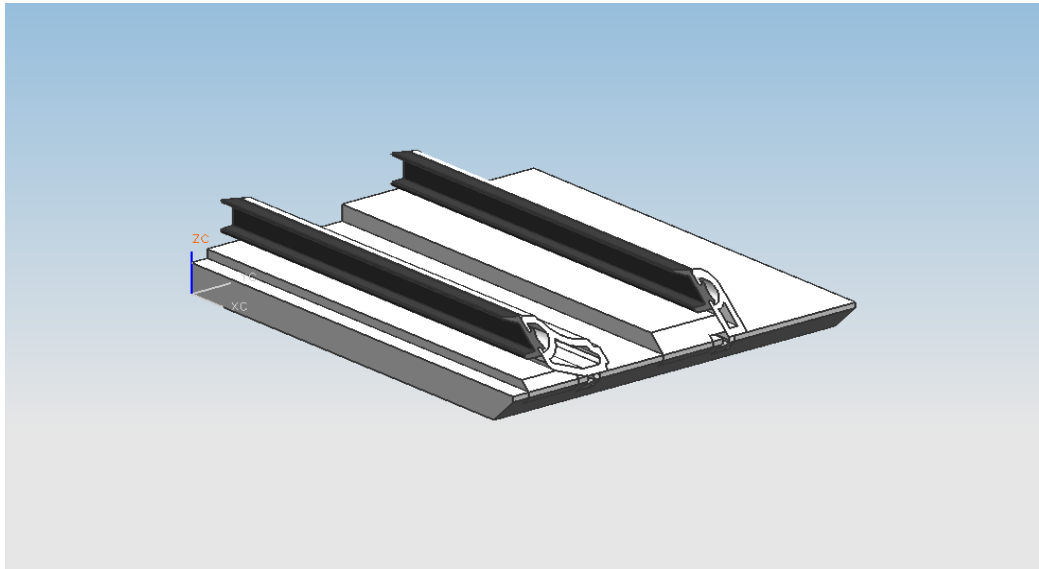

**CONTRAFORMA CORTAR JUNQUILLOS**

**PRECIO POR CONJUNTO  
PRECIO 750 - 30 % NETO 525 €**

URBAN 2 CABEZALESZ AKS 1200

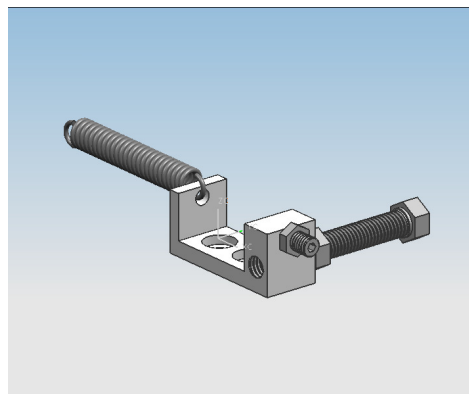

URBAN 4 CABEZALESZ AKS 1400/ETS

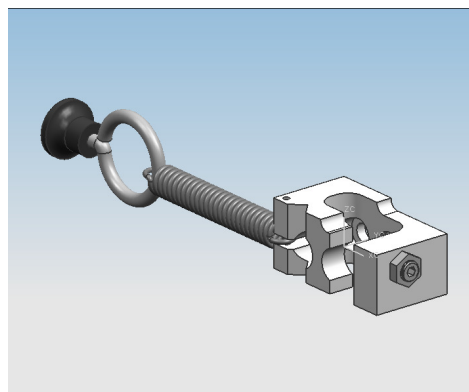

URBAN AKS 1610 4 cabezales

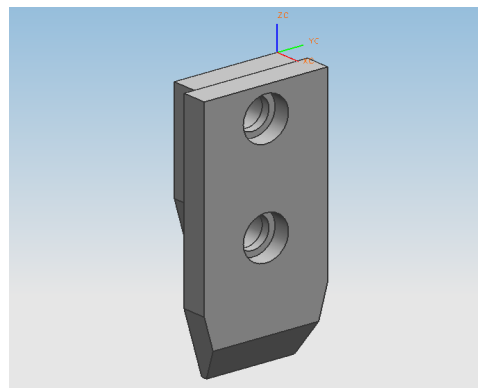

KABAN BB 2030  
KABAN BA 2030

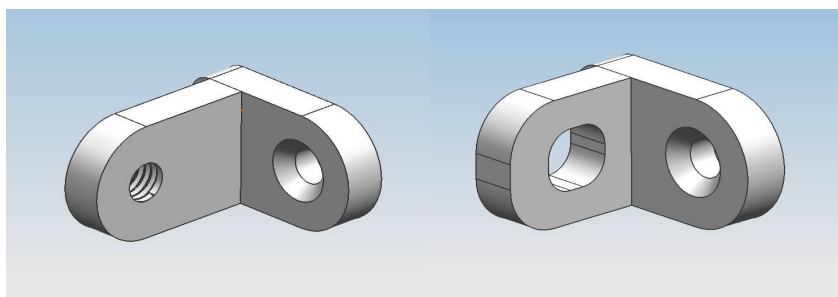

KABAN BA 2020

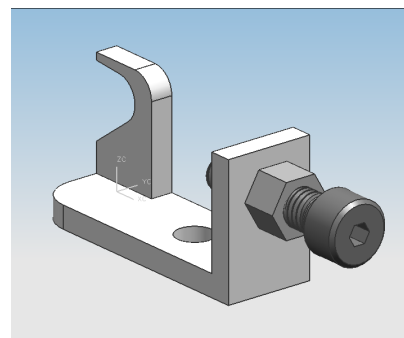

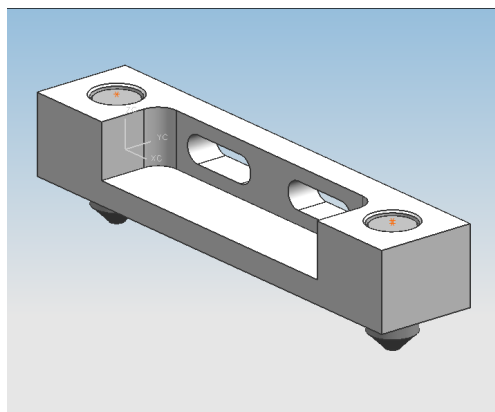

MECAL - MK1 - MK2 - MK4

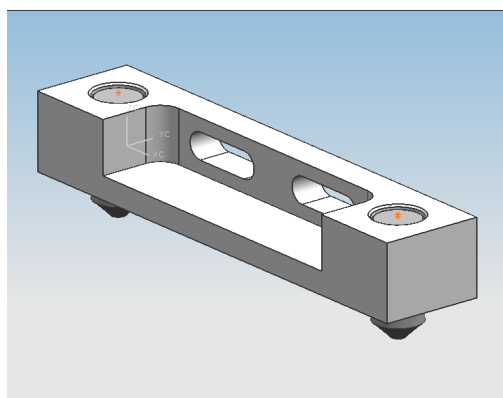

SOENEN HENDRICK CR 802 — MAR 2  
PIEZA CORTA

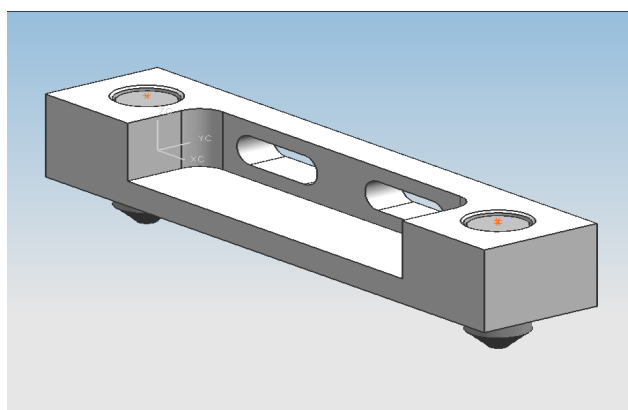

SOENEN HENDRICK CR 80 CR 802  
MAR 2 pieza larga

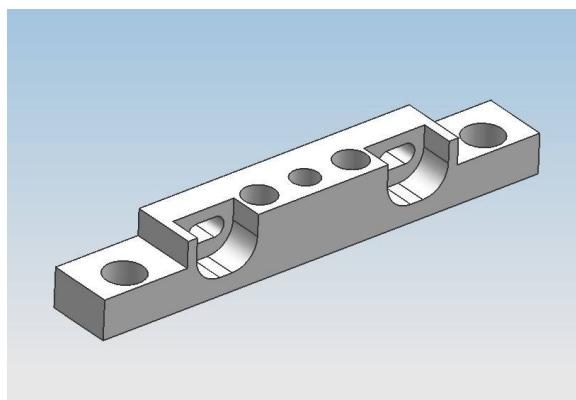

WEGOMA WSA-4L— H

HOLINGER HMS- E

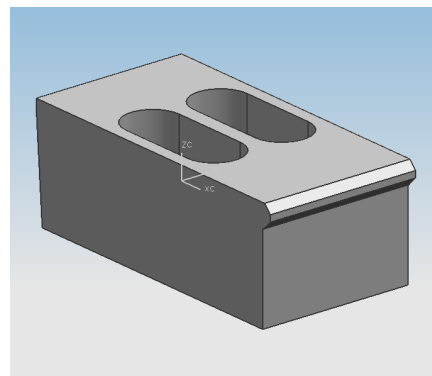

HOLLINGER MSA - 7

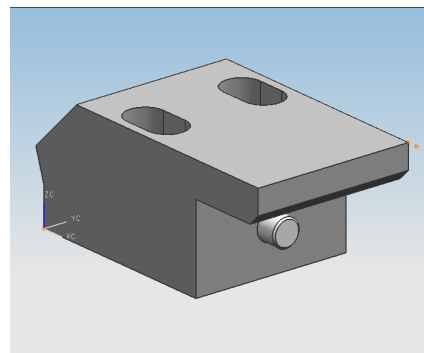

ACTUAL A 312 B90-1 2cabezales  
Pieza corta L155 Pieza larga 200

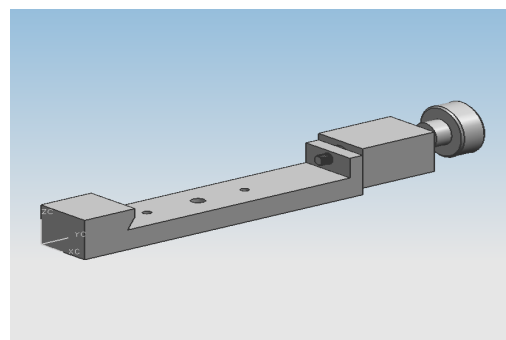

PROFTEQ CUADOS 4 cabezales

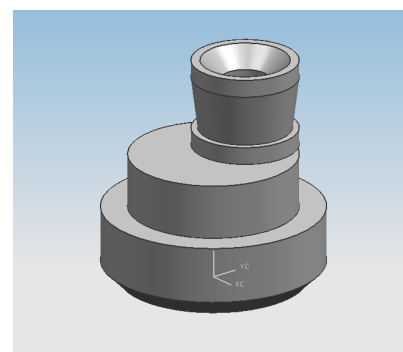

STB - WIN LINE 4cabezales

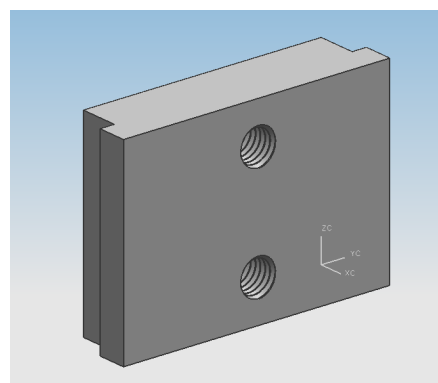

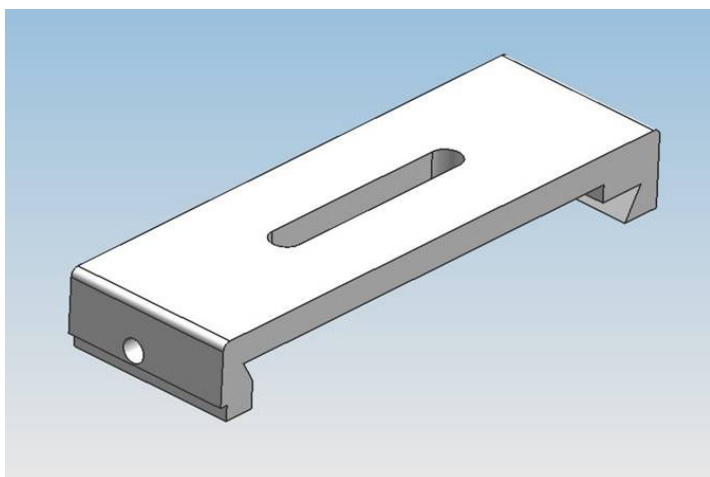

SOENEN HENDRICK Q 4

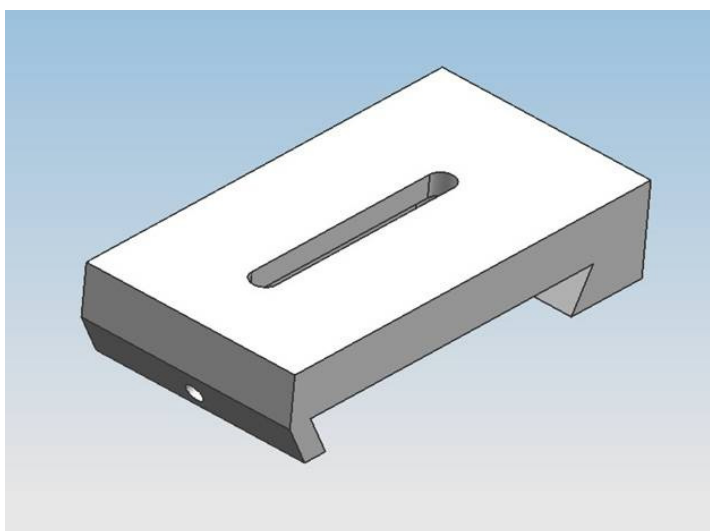

ACTUAL A 312 4 CABEZALES

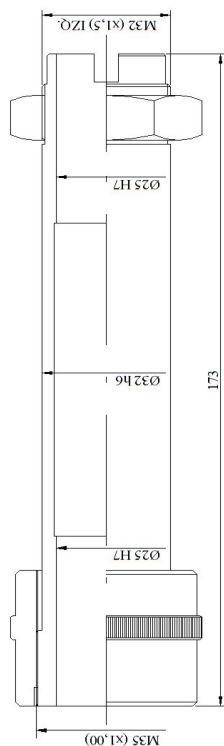

**MAQUINA FO MISTRAL  
FON JET**

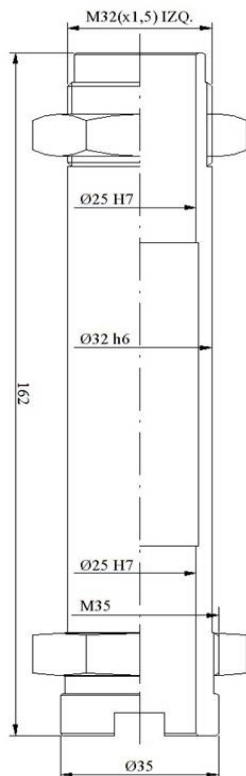

**MAQUINA MECAL FR 711  
GREENMAQ  
ALTECK LIBRA**

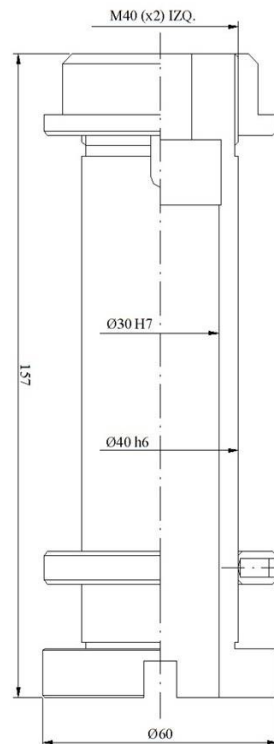

**MAQUINA ROTOX SAF 165**

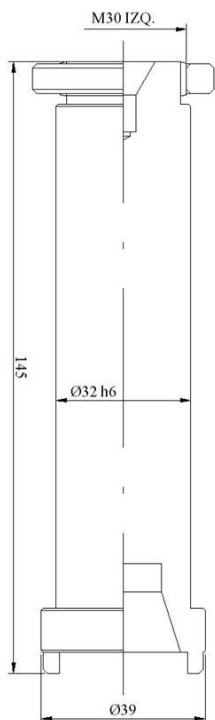

**MAQUINA TEKNA TK 641**

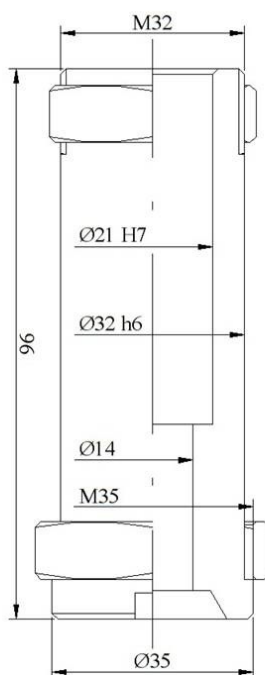

**MAQUINA AYUTOR**

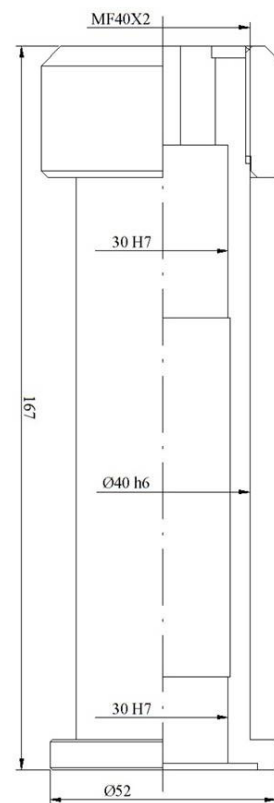

**MAQUINA ELUMATEC AF 221**

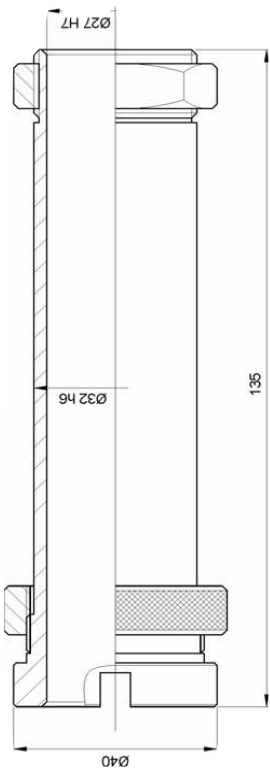

MAQUINA INTEX 3000  
CODMISA C 704

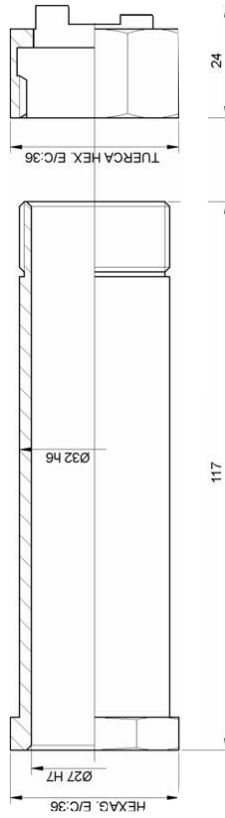

MAQUINA URBAN SVA-21-M7.CRH

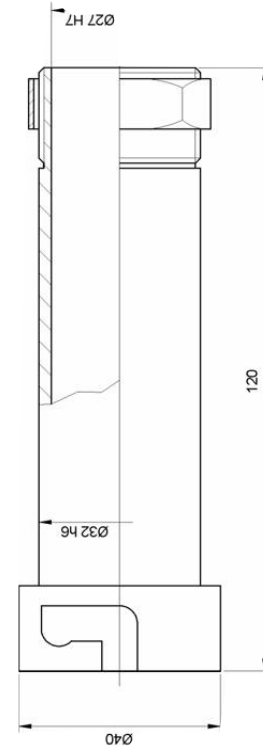

MAQUINA COMALL

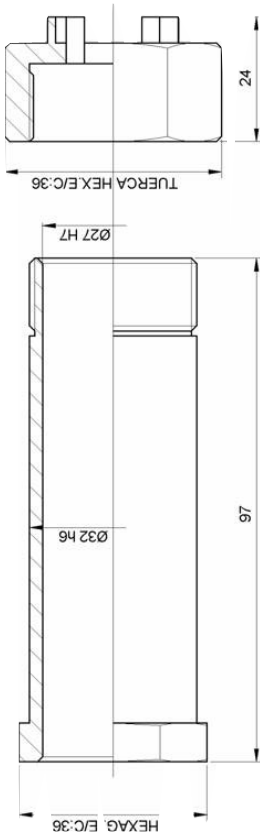

MAQUINA MLA

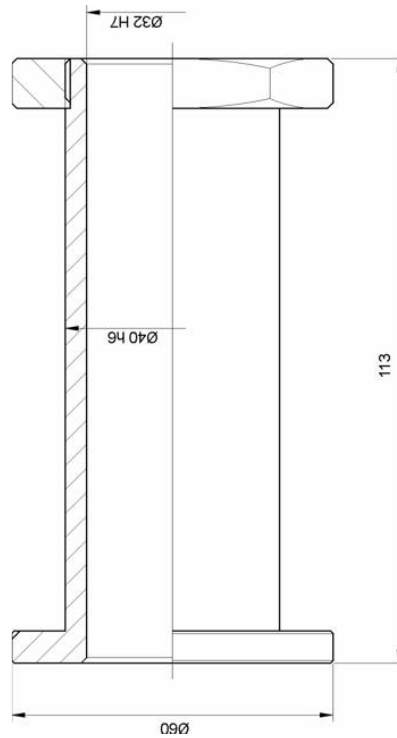

MAQUINA ELUMATEC EV-834

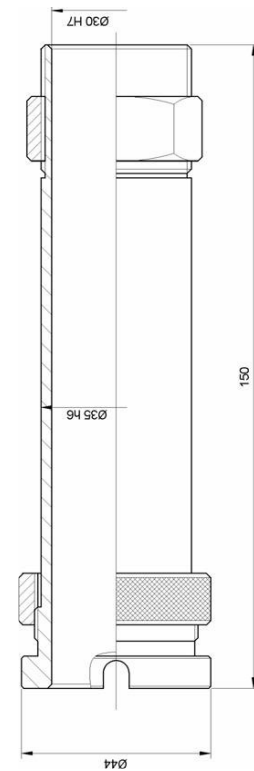

MAQUINA INTEX 3500



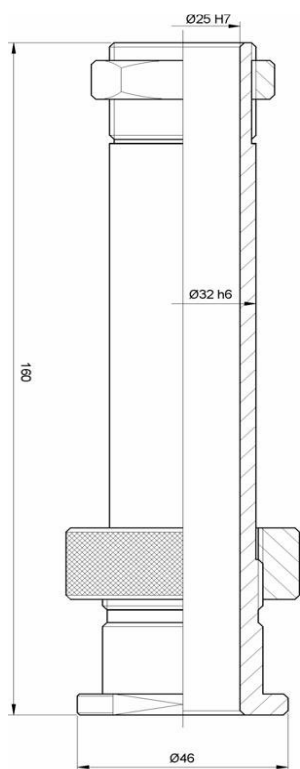

MAQUINA INFISMAL

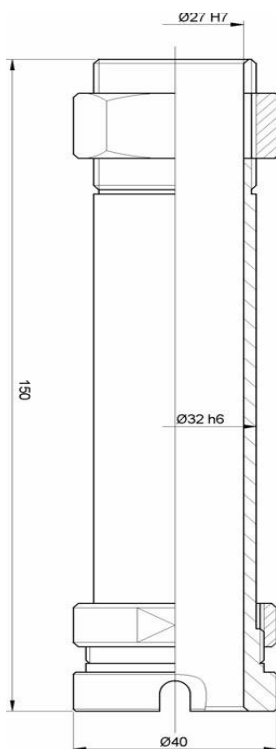

MAQUINA MECAL FR 702

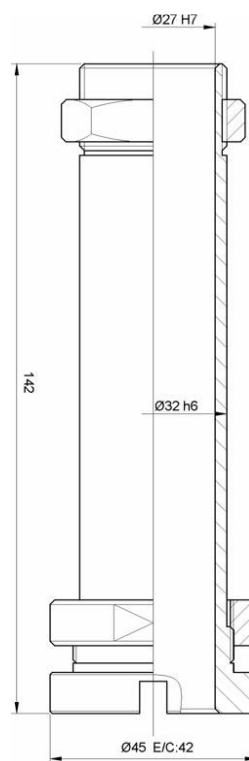

MAQUINA MG RAFRE

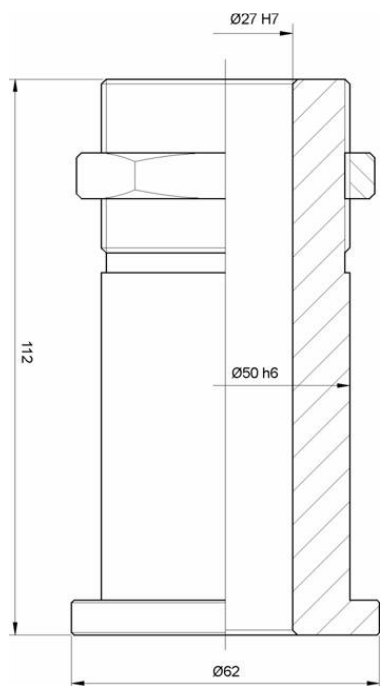

MAQUINA PV.TECNIC  
CAJON DE LIMPIEZA

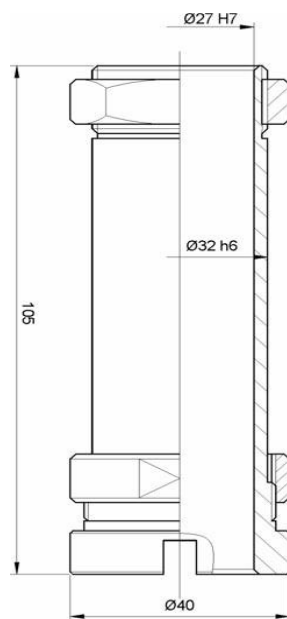

MAQUINA INTEX 2500

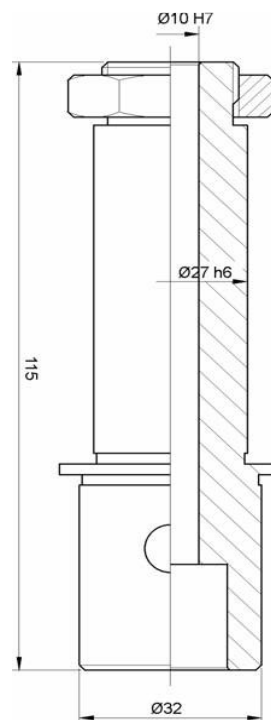

MAQUINA VALLE

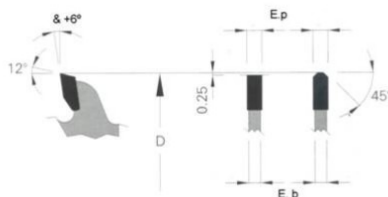

D	d	E.b	E.p	Z	TALADROS	REFERENCIA	PVP	O
200	20	2,2	2,8	64		0055120002006432	B 37	■
250	32	2,6	3,2	80	2/11/63	0055125003208032	B 44	■
275	20	2,6	3,2	72		0055127502007232	B 44	■
300	32	2,6	3,2	72	2/11/63	0055130003207232	B 45	■
300	30	2,6	3,2	96	2/7/42+2/10/60	0055130003209632	B 48	■
300	32	2,6	3,2	96	2/11/63	0055130003209632	B 48	■
300	32	3,0	3,6	96	2/11/63	0055130003209636	C 7	■
330	30	2,6	3,2	102		0055133003010232	C 11	■
350	32	2,6	3,2	84	2/11/63	0055135003208432	C 9	■
350	30	3,0	3,6	108		0055135003010836	C 20	■
350	32	3,0	3,6	108	2/11/63	0055135003210836	C 20	■
400	30	3,2	3,8	96		0055140003009638	C 25	■
420	30	3,2	3,8	96		0055142003009638	C 35	■
450	30	3,2	3,8	108		0055145003010838	C 40	■
450	32	3,2	3,8	108	2/11/63	0055145003210838	C 40	■
500	30	3,8	4,4	120		0055150003012044	C 52	■
500	30	3,8	4,4	160		0055150003016044	E 7	■
550	30	3,8	4,4	140		0055155003014444	E 29	
600	30	3,8	4,4	190		0055160003019044	E 47	
650	40	4,0	5,2	108		0055165004010852	F 2	
650	40	4,4	5,2	180		0055165004018052	E 52	
700	40	4,4	5,2	190		0055170004019052	F 8	
750	40	4,4	5,2	190		0055175004019052	F 16	
760	30	5,0	6,0	72		0055176003007260	F 11	
800	30	4,4	5,2	180		0055180003018052	F 17	
800	40	4,4	5,2	210		0055180004021052	F 27	

KANEFUS A

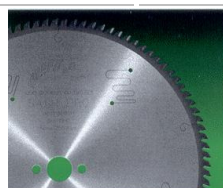

D	d	E.b	E.p	Z	TALADROS	REFERENCIA	PVP	O
250	32	2,4	3,0	80	2/11/63	0059725003008030	C 1	■
300	32	3,0	3,5	96	2/11/63	0059730003209635	C 22	■
350	32	3,0	3,5	108	2/11/63	0059735003210835	C 36	■
400	30	3,0	3,5	120		0059740003012035	C 39	■
450	32	3,4	4,0	144		0059745003214440	E 8	■

Disco para el corte de aluminio, plásticos y PVC.  
 Dispone de ángulo de corte positivo.  
 Recomendado para máquinas de corte con avance automático.  
 Estos discos ofrecen una menor resistencia a la hora de realizar los cortes.

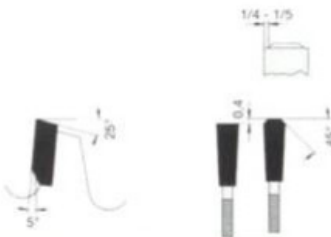

D	d	E.b	E.p	Z	TALADROS	REFERENCIA	PVP	O
150	20	2,0	2,8	42		0055215002004228	B 29	■
175	20	1,6	2,1	68	Junquilladoras	0055217502006821	C 6	■
180	20	2,0	2,8	42		0055218002004228	B 32	■
200	20	2,2	3,0	48		0055220002004830	B 29	■
200	32	2,2	2,6	80	Junquilladoras	0055220003208026	B 32	■
200	30/32	1,8	2,2	100	Junquilladoras	0055220003210022	B 40	■
225	32	2,2	2,6	80	Junquilladoras	0055222503206026	B 32	■
250	30	2,6	3,2	60	2/7/42+2/10/60	0055225003006032	B 32	■
250	32	2,6	3,2	60	2 / 11 / 63	0055225003206032	B 32	■
250	32	2,6	3,2	80	2 / 11 / 63	0055225003208032	B 44	■
250	30	2,6	3,2	100		0055225003010032	B 48	■
250	20	1,8	2,2	120	Junquilladoras	0055225002012022	C 1	■
300	30	2,6	3,2	96	2/10/60	0055230003209636	B 52	■
300	32	3,0	3,6	96	2 / 11 / 63	0055230003209636	C 7	■
350	32	3,0	3,6	108	2 / 11 / 63	0055235003210836	C 20	■
380	32	2,8	3,4	102		0055238003210234	C 30	■
400	30	3,2	3,8	96		0055240003009638	C 25	■
400	30	3,2	3,8	120		0055240003012038	C 35	■
450	30	3,2	3,8	96		0055245003009638	C 37	■
450	30	3,2	3,8	108		0055245003010838	C 40	■
500	30	3,2	3,8	120		0055250003012038	C 52	■



DISCOS BISEL 45° PARA MAQUINA CORTAR JUNQUILLOS DE PVC

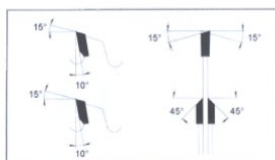

D	d	E.b	E.p	Z	MAQUINA	REFERENCIA	PVP	O
92 R	30	2,5	3,0	24	Rotox	0059209203002430	B 31	■
92 L	30	2,5	3,0	24	Rotox	0059109203002430	B 31	■
95 R	20	1,6	2,1	20	Haffner	0059209502002021	B 14	■
95 L	20	1,6	2,1	20	Haffner	0059109502002021	B 14	■
95 R	32	2,0	2,5	24	Kaban- strongbull	0059209503202425	B 15	■
95 L	32	2,0	2,5	24	Kaban- strongbull	0059109503202425	B 15	■
98 R	32	2,0	3,0	36	Elu	0059209803203630	B 40	■
98 L	32	2,0	3,0	36	Elu	0059109803203630	B 40	■
103 R	32	1,6	2,1	24	Wegoma- Urban	0059210303202421	B 22	■
103 L	32	1,6	2,1	24	Wegoma- Urban	0059110303202421	B 22	■
175 R	32	1,6	2,5	68	Protec	0059217503206825	C 10	■
175 L	32	1,6	2,5	68	Protec	0059117503206825	C 10	■

Disco para corte de aluminio, plásticos y PVC. Con Ángulo de corte negativo.  
Recomendado tanto para máquinas con avance manual o automático

Estos discos ofrecen una mayor resistencia al corte, sin embargo resisten mejor los posibles accidentes

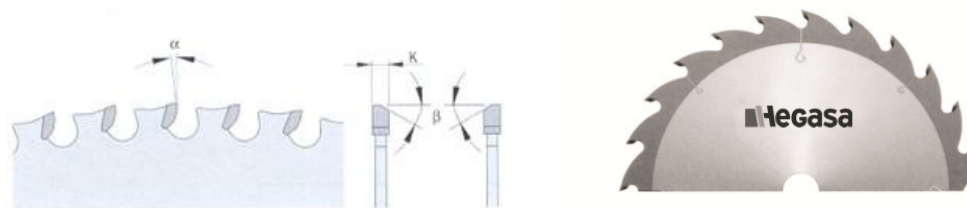

Ø Sierra	RPM Maximas
190	8.000
200-210-216	6.000
250	5.900
300	4.900
350	4.200

D	d	E.b	E.p	Z	TALADROS	REFERENCIA	PVP	O
150	16	1,6	2,2	30		0059615001603022	A 51	■
160	16	1,6	2,2	30		0059616001603022	A 51	■
170	16	1,6	2,2	32		0059617001903222	B 2	■
180	16	1,6	2,2	36		0059618001603622	B 5	■
190	30	1,8	2,2	38		0059619003004822	B 7	■
200	30	1,8	2,2	40		0059620003004022	B 8	■
210	30	1,8	2,2	54		0059621003005422	B 12	■
216	30	1,8	2,2	54		0059621603005422	B 22	■
230	30	1,8	2,2	44		0059623003004422	B 13	■
250	30	1,8	2,2	54		0059625003005422	B 19	■
300	30	1,8	2,2	60		0059630003006022	B 28	■
300	30	1,8	2,2	80		0059630003008022	B 38	■
350	30	2,0	2,4	80		0059635003008024	B 43	■
355	24,5	2,2	2,6	80		0059635502408026	B 43	■
400	30	2,5	3,0	80		0059640003008030	C6	■

Para corte en “seco” de acero suave e inoxidable, tubos y perfiles de acero, paneles sándwich (tanto en acero como aluminio).

Tener en cuenta las RPM máximas que se indican en la tabla de arriba

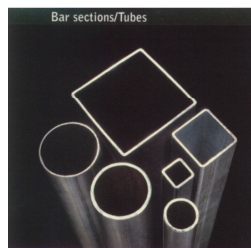

DIMENSIONES	TALADROS	STEAN HSS	PVP	STEAN HSS 5% Co	PVP
200 x 2,0 x 32	2/8,5/45 + 2/11/63	0044020003220	B 13	0044120003220	B 21
225 x 2,0 x 32	2/8,5/45 + 2/11/63	0044022503220	B 13	0044122503220	B 23
250 x 2,0 x 32	2/8,5845+2/12/64+4/9/50	0044025003220	B 16	0044125003220	B 27
250 x 2,0 x 40	2/8,5/45+2/11/63	0044025004020	B 16	0044125004020	B 27
250 x 2,5 x 32	2/8,5/45+2/12/64	0044025003225	B 18	0044125003225	B 28
250 x 2,5 x 40	2/8,5/45 + 2 /12/64	0044025004025	B 18	0044125004025	B 28
275 x 2,5 x 32	2/8,5/45 + 2/12/64	004402753225	B 24	0044127503225	B 36
275 x 2,5 x 40	2/8,5/45 + 2/12/64	0044027504025	B 24	0044127504025	B 36
300 x 2,5 x 32	2/8,5/45 + 2/12/64+ 2/12,5/75	0044030003225	B 33	0044130003225	B 49
300 x 2,5 x 40	2/8,5/55 + 4/12/64	0044030004025	B 33	0044130004025	B 49
315 x 2,5 x 32	2/8,5/45 + 2/12/64+2/12,5/75	0044031503225	B 37	0044131503225	C 1
315 x 2,5 x 40	2/9/55 + 4/12/64	0044031504025	B 37	0044131504025	C 1
350 x 2,5 x 32	2/8,545 + 2/12/64 + 2/12,5/75	0044035003225	B 53	0044135003225	C 24
350 x 2,5 x 40	2/9/55 + 4/12/64	0044037004030	B 53	0044135003225	C 24

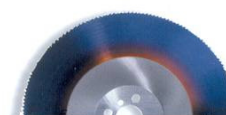

DIMENSIONES	TALADROS	TITANIO	PVP	PERFORMANCE 2000	PVP
250 x 2,5 x 32	2/8,5/45 + 2/11/63	0044225003225	B 36	0044325003225	B 48
250 x 2,5 x 40	2/8,5/45 + 2/11/63	0044225004025	B 36	0044325004025	B 48
275 x 2,5 x 32	2/8,5/45 + 2/11/63	0044227503225	B 44	0044327503225	C 6
275 x 2,5 x 40	2/8,5845+2/12/64+4/9/50	0044227504025	B 44	0044327504025	C 6
300 x 2,5 x 32	2/8,5/45+2/11/63	0044230003225	C 5	0044330003225	C 20
300 x 2,5 x 40	2/8,5/45+2/12/64	0044230004025	C 5	0044330004025	C 20
315 x 2,5 x 32	2/8,5/45 + 2 /12/64	0044231503225	C 8	0044331503225	C 27
315 x 2,5 x 40	2/8,5/45 + 2/12/64	0044231504025	C 8	0044331504025	C 27
350 x 2,5 x 32	2/8,5/45 + 2/12/64	0044235003225	C 32	0044335003225	C 52
350 x 2,5 x 40	2/8,5/45 + 2/12/64+ 2/12,5/75	0044235004025	C 32	0044335004025	C 52

STEAM/ANTIGRIP . Consiste en un tratamiento superficial mediante la deposición de una capa de óxido anti-desgaste. La micro estructura de esta capa tiene la propiedad de ser porosa, lo que junto con el uso de un refrigerante produce un mejor enfriamiento y lubricación. Como resultado de estas propiedades se reduce el riesgo de que el disco gripe por rozadura.

TITANIO. Con el recubrimiento de nitruro de titanio el disco adquiere un color dorado. Las principales ventajas con respecto al resto de sierras son las siguientes.

- Mayor velocidad de corte ( 50 – 100%)
- Mayor vida útil ( 100-300 %)
- Menor resistencia a la fricción, y menor desgaste.

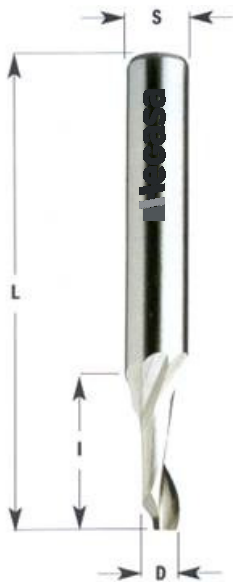

D	S	I	L	Z	REFERENCIA	PVP
3	8	12	60	1	U201,030,R	A 23
4	8	12	60	1	U201,040,R	A 23
4	8	40	100	1	U201,041,R	A 28
4	8	12	100	1	U201,042,R	A 28
5	8	14	70	1	U201,050,R	A 23
5	8	40	100	1	U201,051,R	A 28
5	8	14	100	1	U201,052,R	A 28
5	8	14	120	1	U201,053,R	A 28
5	8	25	70	1	U201,054,R	A 28
5	8	25	100	1	U201,055,R	A 30
5	8	40	120	1	U201,056,R	A 32
6	8	14	70	1	U201,060,R	A 23
6	8	40	100	1	U201,061,R	A 28
6	8	14	100	1	U201,062,R	A 28
6	8	25	70	1	U201,063,R	A 28
7	8	14	70	1	U201,070,R	A 28
8	8	14	80	1	U201,080,R	A 23
8	8	30	100	1	U201,081,R	A 28
8	8	14	100	1	U201,082,R	A 28
8	8	14	120	1	U201,083,R	A 28
8	8	25	80	1	U201,084,R	A 30
8	8	25	120	1	U201,085,R	A 32
9	8	14	80	1	U201,090,R	A 28
10	8	14	80	1	U201,100,R	A 28
10	8	14	100	1	U201,101,R	A 30
10	8	14	120	1	U201,102,R	A 32
12	8	14	80	1	U201,120,R	A 32

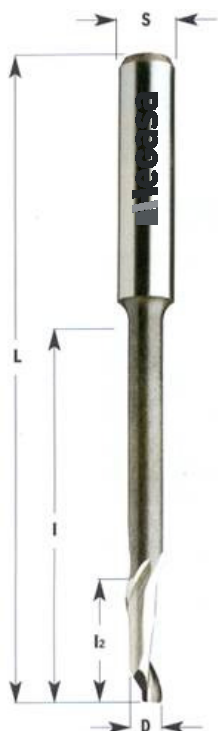

D	S	I	L	Z	REFERENCIA	PVP
4	8	16/55	90	1	U202,040,R	A 28
5	8	14/35	80	1	U202,050,R	A 23
5	8	14/35	120	1	U202,051,R	A 28
5	8	16/55	90	1	U202,052,R	A 28
5	8	18/35	100	1	U202,053,R	A 30
5	8	20/45	100	1	U202,054,R	A 31
6	8	14/55	85	1	U202,060,R	A 28
6	8	14/35	80	1	U202,061,R	A 28
6	8	14/45	90	1	U202,062,R	A 28
8	8	14/60	80	1	U202,080,R	A 28
8	8	14/90	120	1	U202,081,R	A 30
8	8	14/70	100	1	U202,082,R	A 28
8	8	30/70	100	1	U202,083,R	A 31
10	10	14/60	80	1	U202,100,R	A 33
10	10	14/70	100	1	U202,101,R	A 33
10	10	14/95	120	1	U202,102,R	A 34
10	10	30/70	100	1	U202,103,R	A 34

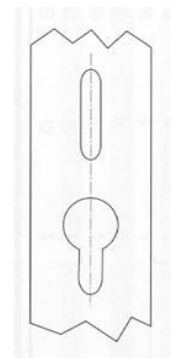

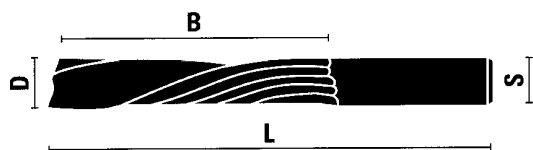

S = D	B	L	Z	REFERENCIA GIRO DERECHA	PVP
4	35	70	1	U101,040,R	A 47
5	35	70	1	U101,050,R	A 52
6	35	80	1	U101,060,R	B 2
8	35	80	1	U101,080,R	B 7
10	35	80	1	U101,100,R	B 13
12	35	80	1	U101,120,R	B 29

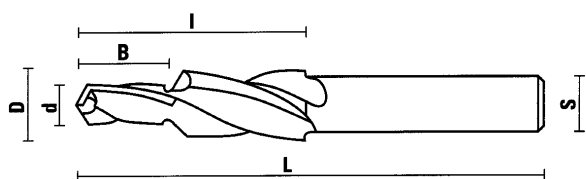

d/D	B/l	L	S	Z	REFERENCIA GIRO DERECHA	PVP
5,5/11,5	12/35	100	10	2	U290,055.R	B 4
6/11,5	12/35	100	10	2	U290,060.R	B 4
6/12	15/35	80	10	2	U290,061.R	B 4
6/14	15/35	80	10	2	U290,062.R	B 7
6,5/13,5	15/35	100	10	2	U290,065.R	B 7
7/13	12/35	100	10	2	U290,070.R	B 7
7/14	12,35	100	10	2	U290,071.R	B 7
7/15	12/35	100	10	2	U290,072.R	B 9
8/15	12/35	100	10	2	U290,080.R	B 9
12,7	41,3		102	2+2	190,508,11*	136
9,53	22,2		76	2+2	190,513,11*	90

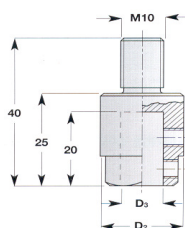

Para utilizar con portabrocas  
Ref 302.080.11  
TARIFA Pág. 190

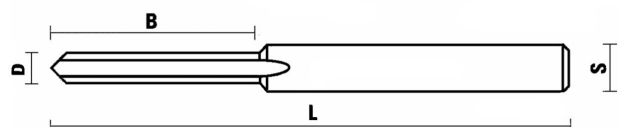

D	B	L	S	Z	REFERENCIA GIRO DERECHA	PVP
5	35	102	8	1	U240,050,R	A 35
5	45	102	8	1	U240,051,R	A 39
5	55	102	8	1	U240,052,R	A 45
6	30	102	8	1	U240,060,R	A 35

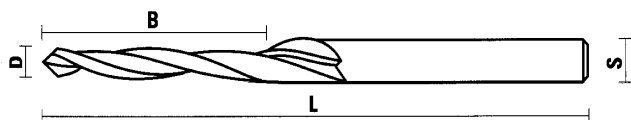

D	B	L	S	Z	REFERENCIA GIRO DERECHA	PVP
5	40	100	8	2	U 241,050,R	A 35

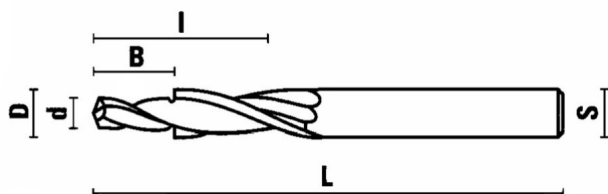

d/D	B/i	L	S	Z	REFERENCIA GIRO IZQUIERDAS	PVP
3/6	8/15	60	6	2	U230,030,R	A 35

MANDRINO PORTA PINZAS DE PRECISIÓN ISO 30

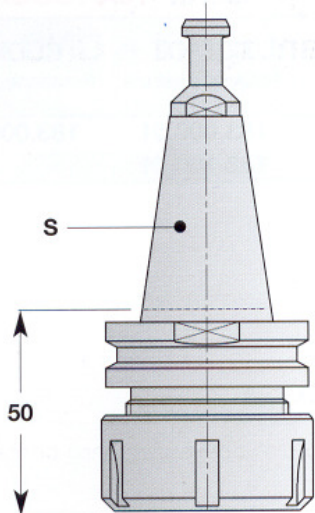

MARCA DE LA MAQUINA	REFERENCIA GIRO DERECHA	REFERENCIA GIRO IZQUIERDA	PVP
	183,200,01	183,200,02	B 41
	183,210,01	183,210,02	B 41
	183,210,01	183,210,02	B 41

TIRANTE	REFERENCIA	PVP
Ø 12 Ø 8 PARA MANDRINO 183,200	995,200,00	A 34
Ø 13 Ø 8 PARA MANDRINO 183,210	995,201,00	A 34
Ø 12,8 Ø 9 PARA MANDRINO 183,220	995,202,00	A 34

PINZA ER 32  
TUERCA DE APRIETE PINZA 992.183.01– 992.183.02

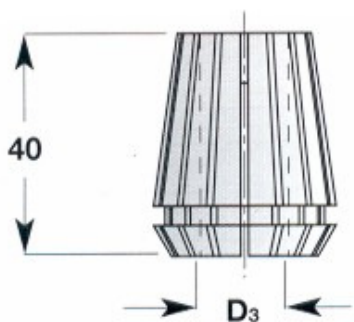

PINZA ELÁSTICA BICÓNICA ER- 32

Para mandrinos: 183.000 / 183.100 / 183.200  
183.250 / 183.300 / 183.400

D <sub>3</sub> = Ø MANGO HERRAMIENTAS	REFERENCIA	PVP
3	184,030,00	A 39
4	184,040,00	A 39
5	184,050,00	A 39
6	184,060,00	A 39
7	184,070,00	A 39
8	184,080,00	A 39
10	184,100,00	A 39
12	184,120,00	A 39
13	184,130,00	A 39
14	184,140,00	A 39
16	184,160,00	A 39
18	184,180,00	A 39
19	184,190,00	A 39
20	184,200,00	A 39

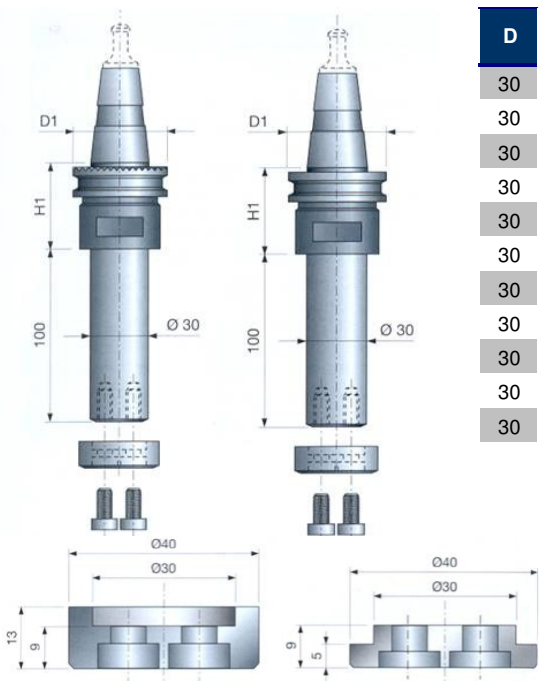

D	MANGO	H1	L	MAQUINA	REFERENCIA	PVP
30	ISO 30	35	70		T128,790,N	B 47
30	ISO 30	35	100		T128,800 N	B 47
30	ISO 30	35	70		T128,791,N	B 47
30	ISO 30	35	100		T128,801,N	B 47
30	ISO 30	35	70		T128,792,N	B 47
30	ISO 30	35	100		T128,802,N	B 47
30	ISO 30	35	100		T128,804,N	C 50
30	ISO 30	35	100		T128,805N	C 45
30	ISO 30	35	100		T128,850N	C 45
30	ISO 30	39	70		T128,690N	C 8
30	ISO 30	39	100		T128,700N	C 8



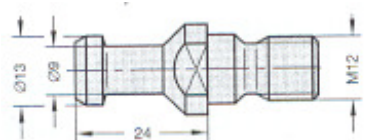

**Nº 1**  
 IMA - MAKA - REICHENBACHER - WECKE  
 BULLERI - COSMEC - LARI E LARI - ESSETEAN

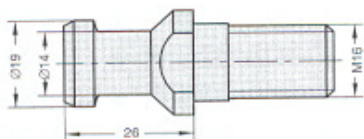

**Nº 2**  
 IMA - MAKA - REICHENBACHER - STEGHERR

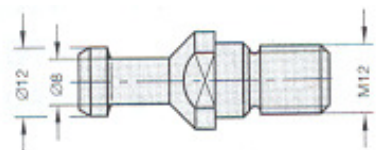

**Nº 3**  
 BIESSE antes del 09/1992

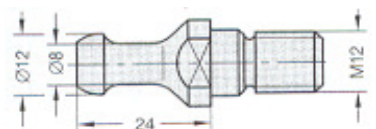

**Nº 4**  
 BIESSE después del 10/1992 ( motores HSD )  
 EGURKO- ORTZA - MASTERWOOD - BULLERI

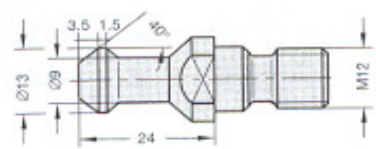

**Nº 5**  
 ALBERTINI - VITAP - MASTERWOOD  
 BELLOTTI ( Motores Colombo)

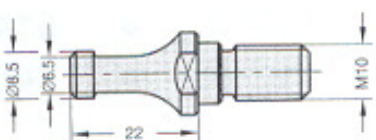

**Nº 6**  
 MORBIDELLI - SCM

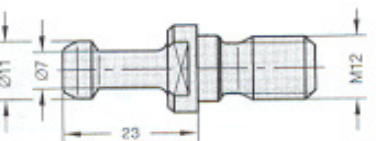

**Nº 7**  
 SHODA

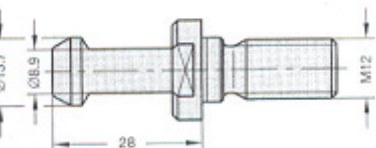

**Nº 8**  
 HEIAN

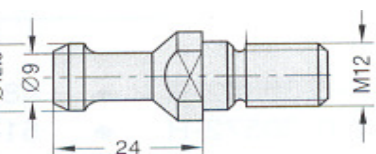

**Nº 9**  
 CMS

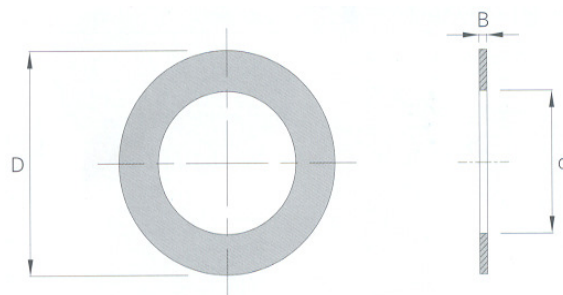

PVC

d	D	H	REFERENCIA	PVP
30	50	2	0171303005000200	A 8
30	50	3	0171303005000300	A 8
30	50	4	0171303005000400	A 9
30	50	5	0171303005000500	A 9
30	50	6	0171303005000600	A 10
30	50	7	0171303005000700	A 10
30	50	8	0171303005000800	A 11
30	50	9	0171303005000900	A 12
30	50	10	0171303005001000	A 13
30	50	11	0171303005001100	A 13
30	50	12	0171303005001200	A 14
30	50	14	0171303005001400	A 14
30	50	15	0171303005001500	A 14
30	50	16	0171303005001600	A 16
30	50	18	0171303005001800	A 16
30	50	20	0171303005002000	A 17
30	50	25	0171303005002500	A 20
30	50	30	0171303005003000	A 21
30	50	40	0171303005004000	A 22
30	50	50	0171303005005000	A 24

d	D	H	REFERENCIA	PVP
32	50	2	0171303205000200	A 13
32	50	3	0171303205000300	A 13
32	50	4	0171303205000400	A 15
32	50	5	0171303205000500	A 15
32	50	6	0171303205000600	A 16
32	50	7	0171303205000700	A 16
32	50	8	0171303205000800	A 17
32	50	9	0171303205000900	A 17
32	50	10	0171303205001000	A 18
32	50	11	0171303205001100	A 18
32	50	12	0171303205001200	A 19
32	50	14	0171303205001400	A 20
32	50	15	0171303205001500	A 20
32	50	16	0171303205001600	A 21
32	50	18	0171303205001800	A 21
32	50	20	0171303205002000	A 22
32	50	25	0171303205002500	A 23
32	50	30	0171303205003000	A 24
32	50	40	0171303205004000	A 27
32	50	50	0171303205005000	A 30

D	d	H	REFERENCIA	PVP
40	60	2	0171304006000200	A 8
40	60	3	0171304006000300	A 9
40	60	4	0171304006000400	A 9
40	60	5	0171304006000500	A 10
40	60	6	0171304006000600	A 11
40	60	7	0171304006000700	A 11
40	60	8	0171304006000800	A 12
40	60	9	0171304006000900	A 12
40	60	10	0171304006001000	A 13
40	60	11	0171304006001100	A 13
40	60	12	0171304006001200	A 14
40	60	14	0171304006001400	A 14
40	60	15	0171304006001500	A 15
40	60	16	0171304006001600	A 17
40	60	18	0171304006001800	A 17
40	60	20	0171304006002000	A 19
40	60	25	0171304006002500	A 20
40	60	30	0171304006003000	A 22
40	60	40	0171304006004000	A 24
40	60	50	0171304006005000	A 27

d	D	H	REFERENCIA	PVP
50	70	2	0171305007000200	A 8
50	70	3	0171305007000300	A 9
50	70	4	0171305007000400	A 10
50	70	5	0171305007000500	A 10
50	70	6	0171305007000600	A 12
50	70	7	0171305007000700	A 12
50	70	8	0171305007000800	A 12
50	70	9	0171305007000900	A 13
50	70	10	0171305007001000	A 14
50	70	11	0171305007001100	A 14
50	70	12	0171305007001200	A 15
50	70	14	0171305007001400	A 16
50	70	15	0171305007001500	A 16
50	70	16	0171305007001600	A 18
50	70	18	0171305007001800	A 19
50	70	20	0171305007002000	A 19
50	70	25	0171305007002500	A 21
50	70	30	0171305007003000	A 23
50	70	40	0171305007004000	A 25
50	70	50	0171305007005000	A 28

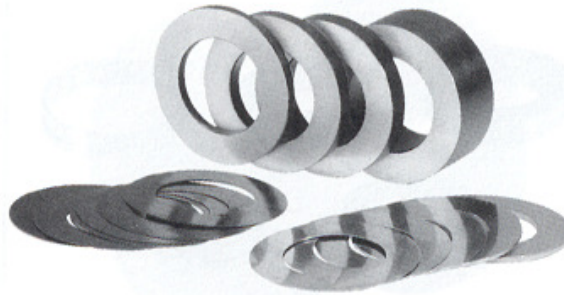

Juego de anillos separadores para el relleno de ejes de máquinas. Compuesto por 21 anillos de las siguientes medidas:

2-3-4-5-6-7-8-9-10-11-12-14-15-16-18-20-25 - 30-40 y 50 mm

d	D	REFERENCIA	PVP
30	50	0171303005010000	C 25
32	50	0171303205010000	C 42
40	60	0171304006010000	C 22
50	70	0171305007010000	C 27

Juego de anillos decimales para regular la separación de herramientas.

Cada juego lleva dos piezas de cada medida de las indicadas en la columna COMPOSICIÓN de la tabla que se muestra a continuación.

d	D	COMPOSICION	REFERENCIA	PVP
20	50	0,1-0,2-0,3-0,5-1,0	0171302005010000	A 15
22	50	0,1-0,2-0,3-0,5-1,0	0171302205010000	A 15
27	50	0,1-0,2-0,3-0,5-1,0	0171302705010000	A 21
30	50	0,1-0,2-0,3-0,5-1,0-2,0-3,0	0171303005010000	A 17
32	50	0,1-0,2-0,3-0,5-1,0-2,0-3,0	0171303205010000	A 23
35	55	0,1-0,2-0,3-0,5-1,0-2,0-3,0	0171303505510000	A 17
40	60	0,1-0,2-0,3-0,5-1,0-2,0-3,0	0171304006010000	A 21
50	70	0,1-0,2-0,3-0,5-1,0-2,0-3,0	0171305007010000	A 21
60	80	0,1-0,2-0,3-0,5-1,0-2,0-3,0	0171306008010000	A 26
65	85	0,1-0,2-0,3-0,5	0171306508510000	A 26